



Center for
Art and Media
Stiftung des
öffentlichen Rechts

Museum for **Museum für**
Contemporary Art **Neue Kunst**

Postal address **Postadresse**
P.O. Box 6909 **Postfach 6909**
D-76049 Karlsruhe

Location **Besuchsadresse**
Lorenzstrasse 19
76135 Karlsruhe
e-mail **info@zkm.de**
www.zkm.de

Tel ++49 (0)7 21-8100-0
Fax ++ 49 (0)7 21-8100-1309

Ms
Steina Vasulka
P.O. Box 100
Route 6
USA-NM 87501 New Mexico

Karlsruhe 30.03.1999 UF/iw
Dr. Ursula Frohne
Durchwahl: -1300
eMail: ufro@zkm.de

Dear Steina Vasulka,

we wish to inform you that our exhibition „Blickwechsel“ will end on April 6, 1999. We will have to start with the dismantling of the installations in order to prepare our new exhibition „Video Cult/ures“ which will be opened on May 5, 1999.

We are pleased to let you know that the exhibition „Blickwechsel“ was very well attended and got an extraordinary response by the public.

As soon as your work is exhibited again, you will be informed immediately.

Best regards

Dr. Ursula Frohne
Kustodin

To: itru@zkm.de
From: Woody & Steina Vasulka <woodyv@santafe.edu>
Subject: Re: Peter Weibel
Cc:
Bcc:
Attached:

At 12:01 PM 3/15/99 +0100, you wrote:

>--

>Ingrid Truxa

>

>ZKM|Zentrum für Kunst und Medientechnologie Karlsruhe

>Center for Art and Media Karlsruhe

>Centre d'Art et de Technologie des Medias de Karlsruhe

>

>Lorenzstrasse 19 - 76135 Karlsruhe

>P.O. Box 6909 - 76049 Karlsruhe

>

>Phone ++49 721 8100-1000 Fax ++49 721 8100-1139

>email: itru@zkm.de <http://www.zkm.de>

>=====

>

>

Empfänger / Adresse: Stichting Steim

Zu Händen / To: Steina Vasulka

Faxnummer / Fax number: 0031-20-6264262

Absender / Sender: Ursula Frohne

Seitenzahl gesamt /
Total number of pages: 2

Institute for Visual Media

Institute for
Music and Acoustics

Media Library

Media Museum

Museum for
Contemporary Art

26. August 1996

Ursula Frohne

Dear Steina:

As your visit to Karlsruhe is coming closer, I would like to ask you the following questions, concerning "Borealis" which you might be able to answer once you are here.

As you know, we received an equipment list for "Borealis" as part of our purchase contract with you. The contract however, only contains the general specifications of the hardware for the installation. To organize the permanent installation of your piece here in Karlsruhe we would need the exact names of the brands for the equipment. It would be a great help for us, if you could give Rudolf a list of the brand names for the hardware pieces which the ZKM should ideally use for the installation of "Borealis"? For example: What kind of video beamers or which brand of laser-disc-players would you recommend? And finally, which producer of the audio equipment would you prefer regarding the required sound quality?

I also wanted to clarify, when and how we are going to receive the extra set of Betacam copies which you confirmed in the contract to submit to the ZKM. Did you already include those copies in the shipment to the Guggenheim Museum or will you or Woody send those separately to Karlsruhe?

Seite 2

As I mentioned to you before, I will be in Amsterdam, while you are coming to Karlsruhe next week. I would therefore appreciate, if you could leave a short note regarding my questions with Rudolf who will pass your instructions on to me.

It might be of interest for you that "Mediascape" is a big success in New York and that the public has attended the exhibition enthusiastically.

Wishing you a pleasant stay here and looking forward to hearing from you.

Best regards.

Sincerely Yours,

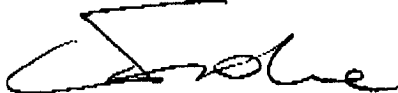
A handwritten signature in black ink, appearing to read 'Ursula Frohne', written in a cursive style.

Ursula Frohne

cc: Woody Vasulka
Rudolf Frieling

Tapelist for ZKM

Submaster copies on Betacam SP

- 1 Evolution 16'
- 2 Don Cherry 12'
- 3 Sketches 27'
- 4 Tissues 6'
- 5 Home 16'
- 6 Vocabulary 5'
- 7 Matrix I/II 38' + 18'
- 8 Orbital Obsessions 25'
- 9 Violin Power 10'
- 10 Flux 9'
- 11 Summer Salt 18'
- 12 Voice Windows 8'
- 13 Lilith 9'
- 14 In the Land of the Elevator Girls 4'
- 15 Reminiscence 5'
- 16 C-Trend 10'
- 16 Artifacts 22'
- 17 The Commission 40'
- 18 Art of Memory 36'
- 19 Pariah 25'

70 min

Totals approx.: 359' (ca. 6 hours)

VHS (or U-matic if copy available) for the Academy archive
not publicly accessible)

- * 6 Artists in Video
- * WGBH Boston "Medium is the Medium"
- * Ars Electronica I,II,III
- * Installations Steina
- * Installations Woody

> + photo + synges / kcsa records Off-to

VHS

Performance Strive

- Other tapes on VHS for the Academy archive:
- * Participation
 - * Golden Voyage
 - * Six Programs for Television
 - * In Search of the Castle
 - * Cantaloup
 - * Progeny
 - * A So Desu Ka

Seite 2

Purchase-list ZKM:

*Dr. B. ...
1030*

- 1 Evolution 16'
- 2 Don Cherry 12'
- 3 Sketches 27'
- 4 Tissues 6'
- 5 Home 16'
- 6 Vocabulary 5'
- 7 Matrix I/II 38' + 18'
- 8 Orbital Obsessions 25'
- 9 Violin Power 10'
- 10 Flux 9'
- 11 Summer Salt 18'
- 12 Voice Windows 8'
- 13 Lilith 9'
- 14 In the Land of the Elevator Girls 4'
- 15 Reminiscence 5'
- 16 C-Trend 10'
- x16 Artifacts 22'
- 17 The Commission 40'
- x18 Art of Memory 36'
- 19 Pariah 25'

VHS for the Academy archive not publicly accessible:

- * Participation
- * Golden Voyage
- * Six Programs for Television
- * In Search of the Castle
- * Cantaloup
- * Progeny
- * A So Desu Ka

Cartagena 1100

PS: Steina, what is your address, tel. and fax at STEIM in Amsterdam???

*1. Lilith
2. Son...
3. VP*

*1. ...
2. ...*

Zentrum für Kunst und Medientechnologie Karlsruhe
Postfach 69 26, 7500 Karlsruhe 1

Memo
to all Infermental participants

**ZENTRUM
FÜR
KUNST UND MEDIEN-
TECHNOLOGIE
KARLSRUHE**
Stiftung des öffentlichen Rechts

Kaiserstraße 64
Postfach 69 26
7500 Karlsruhe 1

Telefon: 0721/93 40-0
Telefax: 0721/93 40 19

Dieter Daniels

☎ 9340-0

March 1991

Dear participants and contributors to the Infermental project,

I am delighted to inform you that Dr. Veruschka Bódy-Másik has recently entrusted the Center for Art and Media Technology (ZKM) with the archives and distribution of all existing Infermental editions from the years 1981 to 1989.

The enclosed information sheet will fill you in on the goals and activities of our center. In addition, we would like to mention that our Media Library will soon catalogue the recently acquired Infermental Archives of video materials and make them accessible to the public.

I hope our Center, which is now in the process of being set up, is of interest to you and I would appreciate your including us on your mailing lists. Please keep us informed of your on-going activities and projects in the area of new media arts.

Sincerely,



Dieter Daniels
(Videodepartment)

Zentrum für Kunst und Medientechnologie Karlsruhe
Postfach 6919, D - 7500 Karlsruhe 1

Vasulkas
RT6, Box 100
Santa Fe
New Mexico 87501
USA

**ZENTRUM
FÜR
KUNST UND MEDIEN-TECHNOLOGIE
KARLSRUHE
Stiftung des öffentlichen Rechts**

Kaiserstr.64, 7500 Karlsruhe 1
Tel.: 0721/ 9340-0, Fax: 0721/ 9340-19

ZKM Mediathek/Bild
Gartenstr.71, 7500 Karlsruhe 1
Tel.: 0721/9340-400 + 401, Fax: 0721/9340-49

Dr. Dieter Daniels

14. Oktober 1992

Dear Steina, dear Woody,

since we met here in Karlsruhe I didn't hear any news from your side. How are things going? Did you make any progress in the negotiations with the lenders of the Linz-show? I can assure you, that everything we talked about is still valid from our side - the ZKM would be very interested to purchase the whole show or an equivalent of it (in case some pieces have to be replaced).

There was also the spontaneous idea of an retrospective of your work at the ZKM-Multimediale. If you are still interested, I am willing to hold on to this idea. The dates for the next Multimediale will be ca. oct. 15 - nov. 14. 1993.

Please let me know, how things are developing.

yours



Zentrum für Kunst und Medientechnologie Karlsruhe
Postfach 6919, D - 76049 Karlsruhe

Steina and Woody Vasulka
RT 6, Box 100
Santa Fe, NM 87 501

USA

**ZENTRUM
FÜR
KUNST UND MEDIEN-
TECHNOLOGIE
KARLSRUHE
Stiftung des öffentlichen Rechts**

Kaiserstr.64, 76133 Karlsruhe
Postfach 6919, 76049 Karlsruhe
Tel.: 0721/ 9340-0, Fax: 0721/ 9340-19

Institut für Bildmedien
Gartenstr. 71, 76135 Karlsruhe
Tel.: 0721/9340-400, Fax: 0721/9340-49

1. Juli 1993

Dear Steina and Woody,

it looks like I will have the opportunity to visit you in Santa Fe at last. I will be at Siggraph till August the 6th, then flying back to Germany from Los Angeles on August the 10th. So if it is possible Agnes and I could come sometime in between these two dates. Could you suggest when? And could you give some advice about the flight-connections between L.A. and Santa Fe?

Look forward to hear from you,
look forward to see you,

Jeffrey Shaw

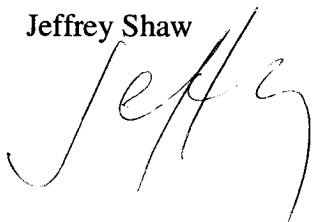
A handwritten signature in black ink, appearing to read 'Jeffrey Shaw', written in a cursive style.

Empfänger/Adressee: The Vasulkas
Zu Händen/To:
Faxnummer/Fax number: 001 505 473 0614
Absender/From: Rudolf Frieling
Seitenzahl gesamt/
Total number of pages: 1

Institut für Bildmedien
Institut für
Musik und Akustik
Mediathek Bibliothek
Medienmuseum
Museum für
Gegenwartskunst

28. November 1995

Dear Steina.

thanks for your detailed schedule. You are very busy and that is good news. (I hear that someone from a music institute in Kassel wants to invite you, too)

As I see it, the two things - working through your archive and the symposion in S.F. on conservation - don't go along since I would definitely want to talk to you both while being in Santa Fe. So, since you will already be in Amsterdam in March and assuming that January will be reserved for the preparation of your show, my suggestion is that I come after the opening of your show at MOMA hoping that you would not be too exhausted afterwards to cope with someone like me asking questions all the time about this and that. Would February 5 to approx. 11 or 12 be okay with you? Since I have to attend the Berlin VideoFest from Feb. 15 on, I cannot come later in February...

best regards

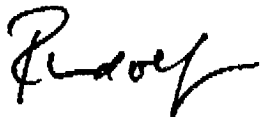

ZKM | Zentrum für Kunst und Medientechnologie Karlsruhe

Empfänger / Adresse: The Vasulkas
Zu Händen / To: Woody Vasulka
Faxnummer / Fax number: 001 - 505 - 473-0614
Absender / Sender: Marianne Meister
Seitenzahl gesamt / Total number of pages: 3

Institute for Visual Media
Institute for Music and Acoustics
Media Library
Media Museum
Museum for Contemporary Art

10. Oktober 1996
0721/9340-202

Dear Woody,

Thank you for your screen-report and your information about the synchronizer.

As far as the mirrors for the single-lens projectors are concerned I add a fax-copy of the dimensions and specifications of the XG-3785E projector.

All the costs that arise from the shipping of synchronizer and screen (also the repair) will pay the Guggenheim Museum because the shipment is also a part of the loan contract.

Best regards.

Marianne Meister

PS. Thank you for the sketch of the split mirror assembly.

The measurement of the lense of the projector can you find on the plan (104 mm).

Dimensions

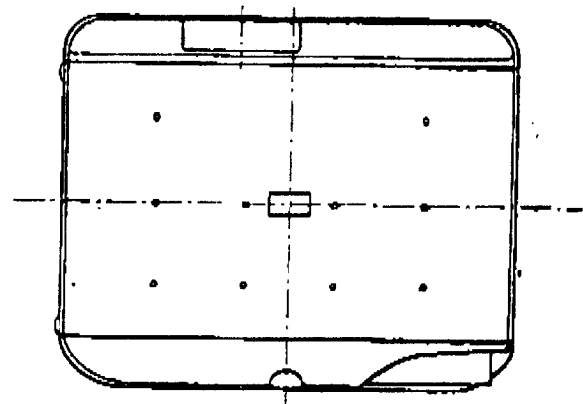

Top View

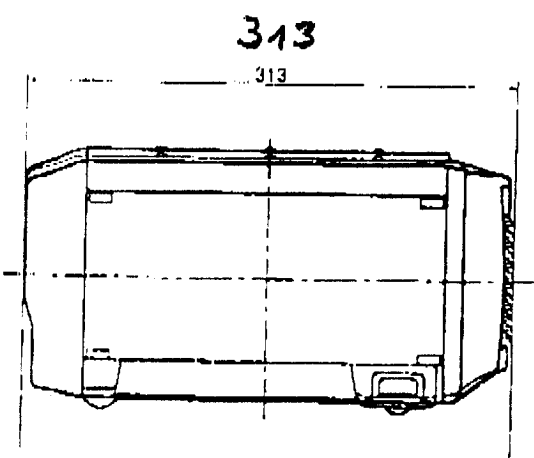

Side View

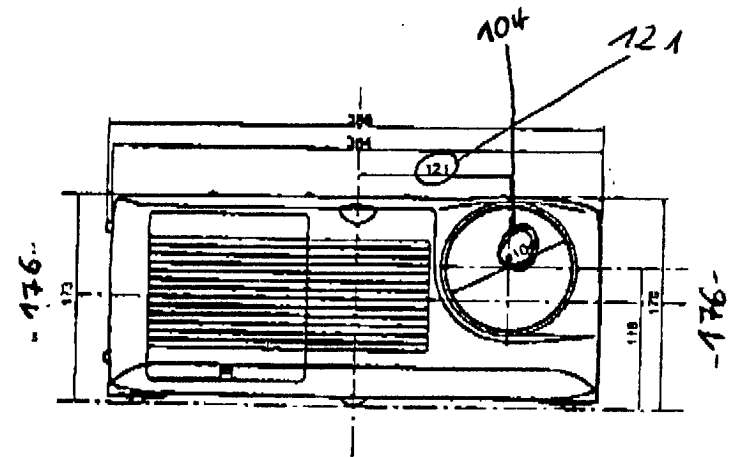

Front View

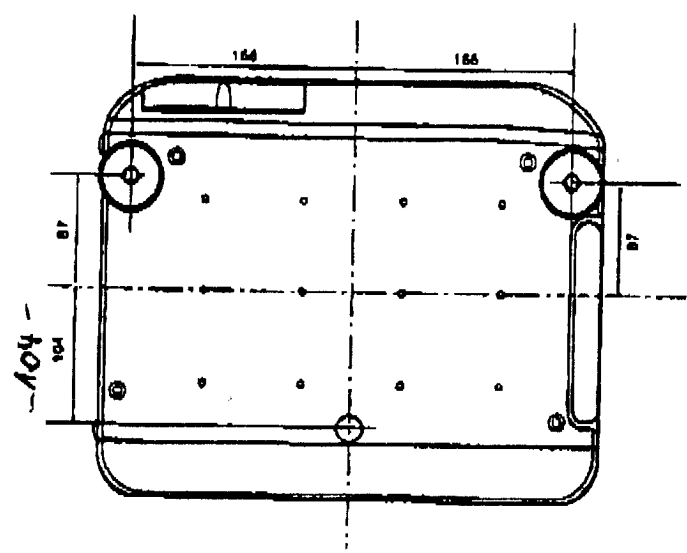

Bottom View

3417
Verbleibende Punkte

[Units: mm]

Empfänger / Adresse:

Zu Händen / To: Steina Vasulka

Faxnummer / Fax number: Heike Staff

Absender / Sender: 001-505-4730614

Seitenzahl gesamt /
Total number of pages: 1

Institute for Visual Media

Institute for
Music and Acoustics

Media Library

Media Museum

Museum for
Contemporary Art

24. März 1997

Dear Steina Vasulka,

Rudolf Frieling gave me your telephone and fax number, when I told him that we would like to ask you to give a performance during the Multimediale, the festival of ZKM after the opening of the new building on 18th of October 1997.

At the 24th of October we start the festival with a mixed programm: a first event with speeches and a second event with four different artists: film and music, a singer controlling computeranimation, a dance film and as the highlight of the concert we could imagine a violin performance of yours controlling video images.

Would you be interested in such a performance in Karlsruhe?

Looking forward to your answer and kindest regards



P.S. My fax number is 0049-721-934039.



INTERNATIONALER
VIDEOKUNSTPREIS | **1998**

Steina Vasulka
RTE 6, Box 100
Santa Fe, NM 87501
USA

/631

Karlsruhe, August 1998

Liebe Teilnehmerin,
lieber Teilnehmer,

Dear applicant for the International
Award for Video Art,

anbei senden wir Ihnen Ihre als
Beitrag zum "Internationalen
Videokunstpreis 1998" eingereich-
ten Unterlagen zurück.

Enclosed please find the material
you sent us as your contribution to
the "International Award for
Video Art 1998".

Wir bedanken uns für Ihre Teilnah-
me und verbleiben

We thank you very much for your
participation.

mit freundlichem Gruß

Sincerely yours,

Marianne Bruder

Marianne Bruder

Anlage(n)

Encl.

SÜDWESTFUNK:

Präsentationsredaktion
76522 Baden Baden
Telefon +49 7221/92-21-33
Fax +49 7221/92-2178

Zentrum
für
Kunst
und
Medientechnologie
Karlsruhe



Postfach 6909
76049 Karlsruhe
Telefon +49 721/81 00-0
Fax +49 721/81 00-11 39

THE VASULKAS

Beta transfer report (as of December 8):
(total of fifteen cassettes contained in this shipment)

ZKM

1 Evolution	16min	not done	Must use original
2 Don Cherry	12min	not done	
3 Sketches	22min	done	
4 Tissues	6min	done	
5 Home	16min	not done	
6 Vocabulary	5min	done	
7 Matrix 1	28min	done	
8 Matrix 2	28min	done	
9 Orbital Obsessions	25min	done	
10 Violin Power	10min	done	
11 Flux	9min	done	
12 Summer Salt	18min	done	
13 Voice Windows	8min	done	
14 Lilith	9min	done	
15 Elevator Girls	4min	done	
16 Reminiscence	5min	done	
17 C-Trend	10min	done	
18 Artifacts	22min	done	
19 The Commission	40min	not done	ABQ postproduction
20 Art of Memory	36min	not done	ABQ postproduction
21 Pariah	25min	done	

Pg2

ACADEMY (VHS) (total of six cassettes contained in this shipment)

9) **Voice Windows**

by Steina 1986

|8min|

10) **Lilith**

by Steina 1987

|9min|

11) **Elevator Girls**

by Steina, 1989

|4min|

12) **Reminiscence**

Woody Vasulka, 1974

|5min|

13) **C-Trend**

Woody Vasulka, 1974

|10min|

14) **Artifacts**

Woody Vasulka, 1980

|22min|

15) **Pariah**

by Steina and Woody
Vasulka

|25min|

VHS FORMAT (six cassettes):

1) **Six Programs for**

Television (I)

by Steina and Woody
Vasulka, 1978

|3x30min|

2) **Six Programs for**

Television (II)

by Steina and Woody
Vasulka, 1978

|3x30min|

3) **In Search of a
Castle**

Steina and Woody
Vasulka, 1981

|10min|

4) **Golden Voyage**

by Steina and Woody
Vasulka, 1973

46 3838

Seite 2

Purchase-list ZKM:

DONE	1 Evolution 16'	-20	30 5 ----- 150.-	
WAIT	2 Don Cherry 12'	-15		
	3 Sketches 22'	10 -		
DONE	4 Tissues 6'	-16		
WAIT	5 Home 16'	5 -		
	6 Vocabulary 5'			
	7 Matrix I/II 38' + 18'			
DONE	8 Orbital Obsessions 25'			3-5 MIN
	9 Violin Power 10'	10 -		
	10 Flux 9'	10 -		
	11 Summer Salt 18'	-20		6 10-
	12 Voice Windows 8'	10 -		4 20
	13 Lilith 9'	10 -		
	14 In the Land of the Elevator Girls 4'	5 -		1 1/2
MUST WAIT	15 Reminiscence 5'	5 -		
	16 C-Trend 10'	10 -		
	16 Artifacts 22'			
	17 The Commission 40'			
	18 Art of Memory 36'			
	19 Pariah 25'			

VHS for the Academy archive not publicly accessible:

- * Participation
 - * Golden Voyage
 - * Six Programs for Television
 - * In Search of the Castle
 - * Cantaloup
 - * Progeny
 - * A So Desu Ka
- 40
EX 30 212+2
10 }
23 }
18 }
10 }

PS: Steina, what is your address, tel. and fax at STEIM in Amsterdam???

10 30 MIN

DIGITAL BRAD 9 10 MIN

ORANGE STICKER 20 1/2 HOURS
w/ M w

Progeny T' MIN IT 2 1 Hours 45 MIN

6 30
1 1/2 H
9 10
20

RUDOLF @ ZKM.DE

Dear Rudolf,
TO: _____

Dec 3 96

Since the end of the year is near, please send me some info about the protocol we are to follow as the tape/money exchange is concerned. The "not done" is no problem yet, we have only a couple of tapes which may have to be postpone to the beginning of the next year if at all. We think we have a chance to succeed in all this year. So, what is the deadline, how are we to prepare the bills, which way are we sending the tapes etc.

Woody

Here is a repeat of the email I already send you:

A Beta transfer report (as of November 28):

ZKM

1 Evolution	16min	not done	Must use original	20 MIN.
2 Don Cherry	12min	not done	_____	20 MIN
3 Sketches	22min	done	_____	30 MIN
4 Tissues	6min	done	_____	10 MIN
5 Home	16min	not done	_____	20 MIN
6 Vocabulary	5min	done	_____	10 MIN
7 Matrix 1	28min	done	_____	30 MIN
8 Matrix 2	28min	not done	_____	30 MIN
9 Orbital Obsessions	25min	done	_____	30 MIN
10 Violin Power	10min	done	_____	10 MIN
11 Flux	9min	done	_____	10 MIN
12 Summer Salt	18min	done	_____	20 MIN
13 Voice Windows	8min	done	_____	10 MIN
14 Lilith	9min	done	_____	10 MIN
15 Elevator Girls	4min	done	_____	5 MIN
16 Reminiscence	5min	not done	_____	10 MIN
17 C-Trend	10min	done	_____	10 MIN
18 Artifacts	22min	not done	_____	30 MIN
19 The Commission	40min	not done	ABQ postproduction	
20 Art of Memory	36min	not done	ABQ postproduction	
21 Pariah	25min	done	_____	30 MIN

ACADEMY (VHS)

1 Participation (X)		not done	- 60 MIN
- 2 Golden Voyage		not done	- 20 MIN
3 Six Programs for (X)			
Television		not done	
- 4 In search of a Castle		not done	- 20 MIN
- 5 Cantaloup		not done	- 30 MIN
6 Progeny (X)		not done	
- 7 A So Desu Ka		not done	- 20 MIN
