

LARGE SCREEN VIDEO PROJECTORS

	Screen Width	First Day
EIKI LC300 LCD <i>Motorized zoom & focus control Easy set-up - Portable (only 25 lbs.)</i>	Adjustable	225.00 Special pick up 125.00
SONY VPH 1041Q <i>Brightness - 600 lumens</i>	4'-14' Adjustable	350.00
SONY VPH 1042Q <i>(HD - 6C Hybrid Lenses) Brightness - 600 lumens</i>	4'-14' Adjustable	400.00
DOUBLE STACKED SONY 1042Q <i>Brightness - 1200 lumens Includes 2 VPH 1042's and a Chief 2 Tier Stacker</i>		700.00 <i>Package Price</i>
TRIPLE STACKED SONY 1042Q <i>Brightness - 1800 lumens Includes 3 VPH 1042's and a Chief 3 Tier Stacker</i>		1075.00 <i>Package Price</i>
ELECTROHOME MARQUEE 8000 <i>8" CRTs 1100 lumens - brightest CRT projector available</i>	5'-20' Adjustable	800.00
DOUBLE STACKED ELECTROHOME MARQUEE 8000 <i>2200 lumens Includes 2 marquees and stackers</i>	5'-20' Adjustable	1200.00
GE TALARIA PJ5055HB LIGHT VALVE <i>Brightness - 8,000 CRT lumens Variable throw lens: 1.5 / 3.0 / 4.2 / 4.9 / 7.0 (RGB color computer graphics / video)</i>	4'-20' Adjustable	1200.00
GE TALARIA 12K MP LIGHT VALVE <i>Brightness - 13,000 CRT lumens (RGB color graphics / video)</i>	4'-30' Adjustable	2600.00

Experience

All of Mid-Co's technicians are experienced & knowledgeable. They are fast, friendly, and they are on time. They are there to serve you, the customer.

PROJECTOR ACCESSORIES	First Day
67" Retro Cabinets <i>rear screen enclosure for most Video/Data projectors</i>	300.00
Covid Computer Interfaces	50.00
Chief Two Tier Stacker <i>for Sony VPH 1042</i>	50.00
Chief Two Tier Stacker <i>for Sony VPH 1271 or Electrohomes</i>	100.00
Chief Three Tier Stacker <i>For Sony VPH 1042</i>	100.00
GE MLS <i>(Multiple lens system for GE Talaria projectors) This device eliminates the halo around the projected video image & allows for throw distances from .8 to 10 times the screen width.</i>	380.00
Video Adapter <i>for ASK LCD panel</i>	40.00

INFORMATION ON PROJECTOR RENTAL

Our projector rental rates include set up and delivery within the Twin Cities metro area during normal business hours with two exceptions: The special Eiki price is for pick up at Mid-Co only. GE Talaria projectors require a Mid-Co operator. Talaria operators are billed on a per hour basis. Please call for quotes.

(612) 544-3375

COMPUTER SCANNING STANDARDS

	Horiz scan rates kHz	Vert. scan rates Hz
VGA	31.50	60
SVGA	35.156	56
SVGA #2	44.20	70
SVGA #3	61.0	76
SVGA #4	72.16	70
Mac, Mac+, Mac SE	22.23	60
Mac II	35.00	66
SuperMac	48.19	59.3

SIGNAL DISTRIBUTION PRODUCTS & ACCESSORIES

	First Day
VIDEO SWITCHER (vertical interval)	35.00
VIDEO SWITCHER (passive)	10.00
VIDEO DISTRIBUTION AMPLIFIER	10.00
RGB SWITCHER (8 Inputs 40 mHz)	50.00
MARQUEE RGB SWITCHER (350 mHz)	150.00
RGB DISTRIBUTION AMPLIFIER (100 mHz or 180 mHz)	40.00
GROUND LOOP ISOLATOR (Humbucker)	10.00
VGA DISTRIBUTION AMPLIFIER (1 Input - 4 Outputs)	40.00
VIDEO FIBER OPTIC SYSTEM (Broadcast quality - up to 4000')	140.00

VIDEO TAPE PLAYERS/RECORDER

	First Day
VHS PLAYER / RECORDER	25.00
VHS PLAYER (with a projector rental)	10.00
VHS PLAYER or RECORDER (with auto repeat)	50.00
ZENITH SUPER VHS VCR (Hi-Fi Stereo)	75.00
GYR TLC 1800 TIME LAPSE RECORDER	70.00
PHILIPS CDV400 (Multi Laser Disc Player)	50.00
SONY VO-5600 (1/2" U-Matic Player / Recorder)	75.00
SONY VP-9000 (1/2" SP U-Matic Player)	85.00
SONY VO-9600 (1/2" SP U-Matic Player / Recorder)	95.00
SONY BVW-75 BETACAM SP STUDIO RECORDER (Editor with TBC)	425.00

SATELLITE COMMUNICATIONS

	First Day
SATELLITE UPLINK	2500.00
TRANSPONDER TIME (Price per day)	575.00
SATELLITE DOWNLINK (A professional transportable 3.65 meter / 12' AFC satellite dish with fully redundant, broadcast certified electronics. Receives C band or KU band - full or 1/2 transponder. Note: Operator is billed at standard technician rate. Price for Mpls. / St. Paul locations per day)	450.00
SITE SURVEYS (C or KU band in 7 county metro area)	250.00
PROGRAM RECORDING (C or KU band)	call for quote

This catalog is printed on paper manufactured from 50% recycled waste paper including 10% post-consumer fiber.

(612) 544-3375

**LARGE SCREEN
DATA PROJECTORS**

	Screen Width	First Day
ASK IMPACT 16.7 LCD PANEL		200.00
<i>16.7 million colors, 100 to 1 contrast ratio Optional video adapter available</i>		
ELECTROHOME ECP 3101 ACON	5'- 14' Adjustable	500.00
<i>Brightness - 650 lumens RGB band width 60 mHz Automatic convergence Scans 15 - 55 kHz horizontal 45 - 120 Hz vertical</i>		
ELECTROHOME ECP 4101 ACON	5'- 14' Adjustable	650.00
<i>Brightness - 650 lumens RGB band width 70 mHz Automatic convergence Scans 15 - 85 kHz horizontal 45 - 120 Hz vertical</i>		
SONY VPH 1271Q	5'- 20' Adjustable	650.00
<i>Brightness - 650 lumens RGB band width 70 mHz 15 - 85 kHz horizontal 38 - 150 Hz vertical</i>		
DOUBLE STACKED VPH 1271Q		1100.00
<i>Brightness - 1800 lumens Includes 2 1271's and stacker</i>		
ELECTROHOME MARQUEE 8000	5'- 20' Adjustable	800.00
<i>8" CRTs RGB band width 100 mHz Brightness - 1100 lumens 30 - 130 kHz horizontal 38 - 150 Hz vertical</i>		
DOUBLE STACKED ELECTROHOME MARQUEE 8000	5'- 20' Adjustable	1200.00
<i>2200 lumens</i>		

(612) 544 • 3375

PROJECTION SCREENS	Screen Size	Front	Rear	Drape Kit
HI GAIN CURVED	3 1/2' X 5'	40.00		
PORTABLE TRIPOD	Various	10.00		
CINEFOLD	5' x 7'	25.00	25.00	40.00
CINEFOLD	6' x 8'	40.00	40.00	40.00
CINEFOLD	7 1/2' x 10'	40.00	40.00	40.00
CINEFOLD	9' x 12'	40.00	40.00	40.00
CINEFOLD	10 1/2' x 14'	50.00	50.00	50.00
CINEFOLD	15' x 20'	250.00	250.00	90.00

Additional draping available on a per foot basis.



PRICES SUBJECT TO CHANGE WITHOUT NOTICE.

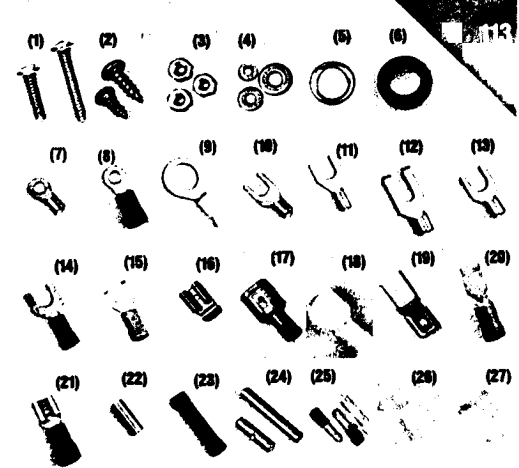
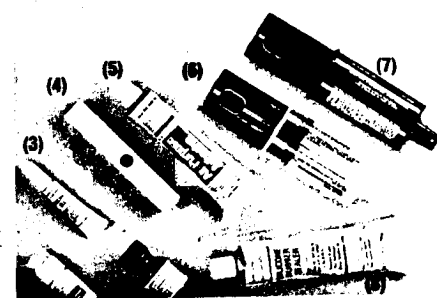
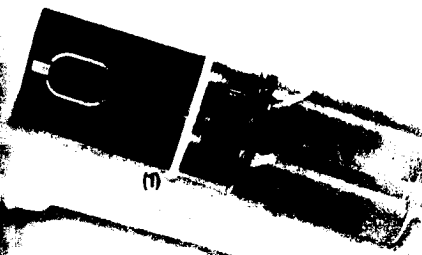

Stick With Us for the Best Glue or Adhesive for Practically Any Job

- (1) One-Minute Epoxy. Super strength without the wait. Automatic mixer. 1 oz. 64-2328 3.79
- (2) Instant-Bonding Glue. 0.11 oz. 64-2308, 1.79
- (3) High-Tech Bonding Gel. Bonds almost anything. With 1/2-oz. accelerator. 64-2306 6.19
- (4) Super Glue Stiek. Pushbutton dispenser means no mess or waste. Bonds on contact. 64-2327, 1.99

- (5) All-Purpose Adhesive. 1 1/4 oz. 64-2307 . . . 1.70
- (6) Twin-Tube Epoxy. No mixing. Pushbutton applicator meters out correct ratio of resin and hardener. 1 oz. 64-2313 2.79
- (7) Plastic Bonder. 1 oz. 64-2305 3.99
- (8) Silicone Rubber Sealant. Resists moisture and remains flexible. Big 3-oz. tube. 64-2314 . . . 2.99

Hardware and Connectors in Handy-Paks, Only \$1.39 Each

Storage Box With Compartments. 8 1/2 x 4 1/4 x 1 1/2". See-through plastic. 64-652 2.99

Polarized Interlocking Connectors Heavy-Duty

Male. 250V Per Circuit				Female. 250V Per Circuit			
Pos.	Amps	Cat. No.	Each	Pos.	Amps	Cat. No.	Each
2	20	274-151	.99	2	20	274-154	.99
6	15	274-152	1.69	6	15	274-155	1.69

Male. 125V Per Circuit				Female. 125V Per Circuit			
Pos.	Amps	Cat. No.	Each	Pos.	Amps	Cat. No.	Each
4	9	274-224	1.09	4	9	274-234	1.09
6	9	274-226	1.39	6	9	274-236	1.39
9	9	274-229	1.59	9	9	274-239	1.59
12	7.5	274-232	1.69	12	7.5	274-242	1.69

Two-Pin Male/Female Set. Handles up to 12 amps, 250VAC per circuit. 274-222 Set 99¢

Pin Extractor

For standard polarized connectors. Remove male or female .093" dia. locking crimp pins easily and without damage. 274-223 4.99



DC Power Connectors

I.D. = Inside Diameter. O.D. = Outside Diameter
(1) Plugs. Fit DC jack of many portables.

O.D.	I.D.	Cat. No.	Pkg. of 2
3.5mm	1.1mm	274-1574	1.79
3.5mm	1.3mm	274-1571	1.79
5.0mm	1.6mm	274-1570	1.69
5.0mm	2.1mm	274-1567	1.69
5.0mm	2.5mm	274-1568	1.69
5.5mm	2.1mm	274-1569	1.69
5.5mm	2.5mm	274-1573	1.49
6.3mm	3.0mm	274-1572	1.59

- (2) Metal Panel-Mount DC Input Jacks. 5.5mm outside diameter, 2.1mm I.D. 274-1563 . . . 1.79 2.5mm I.D. 274-1576 . . . 1.69
- (3) Molded DC Jacks. 5.0mm O.D., 2.1mm I.D. 274-1565, 2/1.49
- (4) Inline Jack. 5.5mm O.D., 2.1mm I.D. 274-1577 . . . 1.89
Inline Jack. 5.5mm O.D., 2.5mm I.D. 274-1578 1.89

Polarized Connectors

Rated 7.5A, 500V maximum per position.

Type	Positions	Cat. No.	Each
Plug	2	274-201	2.19
Socket	2	274-202	2.19
Plug	4	274-204	2.39
Socket	4	274-205	2.39

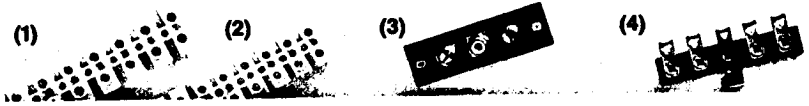

Wire Terminal Strips

- (1) 12-Pos. "Jumbo" European-Style Barrier Strip. Each position accepts two wires. 274-677 . . . 4.19
- (2) 12-Pos. Standard "Euro" Strip. 274-679 . . . 2.39
- (3) 8-Position Standard "Euro" Strip. 274-678 . . . 1.99
- (3) Two Screw Terminals With Phone Jack. Ideal for replacing jacks on speakers, antenna input on radios, or use on projects. 274-620 Pkg. of 2/1.59
- (4) Five-Lug Tie Points. Use center lug for grounding when used on metal chassis. 274-688, Pkg. of 4/1.25

Barrier Strips and Accessories

Dual-Row Barrier Strips. Barriers between the positions help prevent accidental contact and short circuits. Great for projects, alarms, model rail and vehicle hookups.
(1) 2-Position. 274-656 . . . Pkg. of 2/1.49
(2) 4-Position. 274-658 Each 1.49
(6) 6-Position. 274-659 Each 1.59
(8) 8-Position. 274-670 Each 2.19

(3) 8-Position Jumper. Use to connect up to eight terminals on barrier strips. Can be cut for fewer terminals. 274-650 . . . 1.59
(4) Chassis-Mount Feedthrough Barrier Strip. Eight screw terminals with 3/16" solder tabs on rear. 274-653 2.59

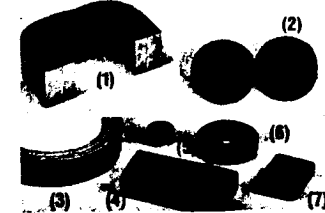

Magnetic Attractions

- (1) Horseshoe Magnet. 7 1/2-pound pull! About 1 1/2 x 1 1/8 x 1/2". 64-1867 . . . 7.99
- (2) Rare-Earth Super-Magnet. Powerful, yet only 1/4" diameter. Pair 1.49
- (3) Magnetic Taps. Holds tools to wall and more. 1/2" x 30". 64-1890 99¢
- (4) High-Energy Ceramic Magnet. About 1 1/8 x 7/8 x 3/8". 64-1877 99¢
- (5)(6)(7) Ceramic Magnets Each 23¢

Type	Cat. No.	11-24	25-99	100-Up
1/2" Button	64-1880	20¢	19¢	17¢
1 1/2" Round	64-1885	Each	Each	Each
1" Rectang.	64-1875			

Fig.	Description	Qty.	Cat. No.
1	Round-Head Machine Screws. 2-56 Machine Screws. 4-40 Machine Screws. 6-32	42	64-3010
2	Pan Head Sheet-Metal Screw Assortment	35	64-3016
3	Steel Machine Hex Nuts. 40 each: 2-56 Steel Machine Hex Nuts. 30 each: 4-40 Steel Machine Hex Nuts. 30 each: 6-32	40	64-3017
4	Flat Washers. 20 each of #2, #4, #6, #8, #10	100	64-3022
5	Control Nuts	23	64-3020
6	Metric Control Nuts	20	64-3063
7	Grommets. 7 ea: 1/4", 3/16", 1/8". 5 ea: 7/16", 1/2"	31	64-3025
8	Solderless Ring Tongues	24	64-3030
9	Solderless Insulated Ring Tongue Assortment	6	64-3040
10	Insulated Large Ring Tongues	24	64-3031
11	Solderless Spade Tongues	10	64-3042
12	Solderless Flanged Spades	24	64-3043
13	Solderless Spade Tongues. 12 ea: (22-18), (16-14) As Above, But Insulated. Five Each	10	64-3035
14	Solderless Insulated Spades (22-14)	8	64-3044
15	Solderless Insulated Spade Tongues	10	64-3033
16	Female Flag Quick-Disconnects	10	64-3046
17	Solderless Insulated M/F Q-Ds (22-14)	8	64-3049
18	NEW! Insulated Female Quick-Disconnects	6	64-3058
19	Single Female to Dual Male Quick-Disconnects	6	64-3061
20	Male Quick-Disconnects	8	64-3038
21	Female Quick-Disconnects	8	64-3039
22	Butt Connectors. 10 ea. (22-18), (16-14)	20	64-3036
23	Insulated Butt Connectors	10	64-3037
24	Aluminum Spacers	24	64-3024
25	Bullet Connectors, Insulated	9	64-3047
26	Ins. Closed-End Connectors, 5 ea.: (32-41), (16-10)	10	64-3041
27	Polypropylene Cable Clamps	18	64-3028

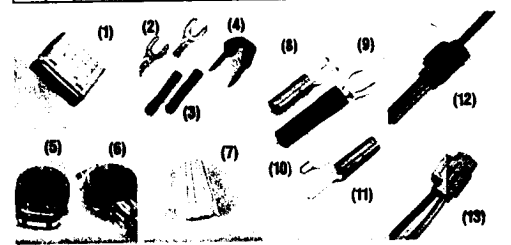

Wire Terminals, Connectors and Staples

Fig.	Description	Qty.	Cat. No.	Price
1	Push-Lock™ Wire Connectors	5	64-3056	1.39
2	Insulation-Piercing Phone Spade Lugs	24	64-3070	1.39
3	Phone Wiring Butt Connectors	24	64-3073	1.39
4	Standard Wire Staples	40	64-2875	.99
5	Phone/Alarm Wire Splices	4	64-3080	1.89
6	Phone Wire UG Tap Connectors	4	64-3081	1.89
7	Wire Connectors	16	64-3057	1.49
8	Small Gold-Plated Terminals*	8	64-402	4.89
9	Large Gold-Plated Terminals*	8	64-401	5.19
10	Solderless Crimp Lugs	100	64-406	2.59
	Insulated Crimp Lugs	75	64-407	2.59
	Antenna Lead Terminals	12	64-408	1.29
11	Gold-Plated Pin Connectors*	4	64-403	3.29
12	Wire Tap-Ins (14-18 gauge)	10	64-3052	1.69
13	Low-Voltage Tap-Ins (18-22 gauge)	7	64-3053	1.69

*For use with our MEGACABLE® speaker wire—see page 116.

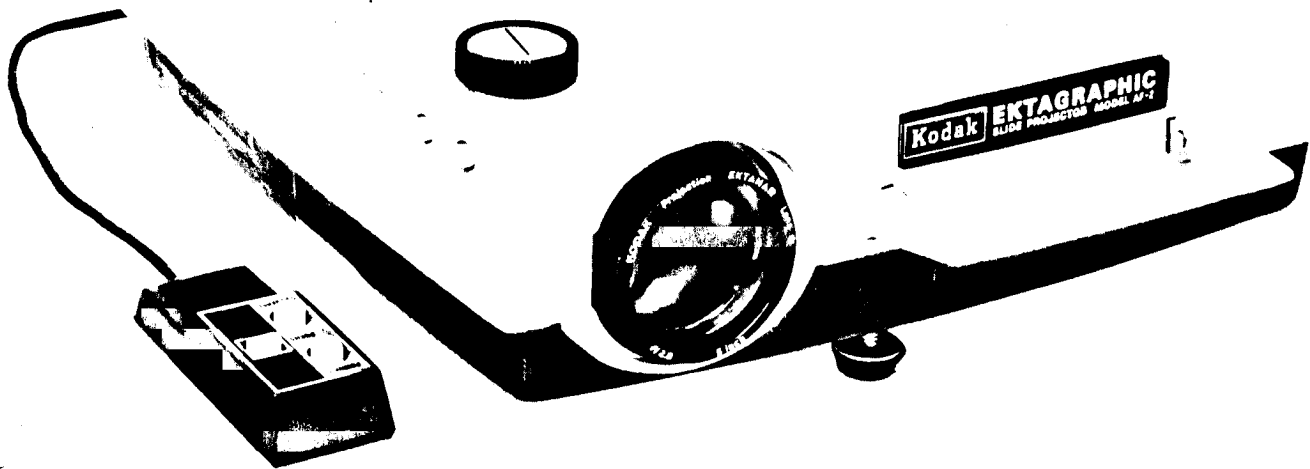

How to use the **KODAK EKTAGRAPHIC** Slide Projector Model AF-2

table of contents

FEATURES OF THE KODAK EKTAGRAPHIC SLIDE PROJECTOR, MODEL AF-2	3
THE CONTROLS AND THEIR FUNCTIONS	4
SETTING UP—THE ROOM AND THE PROJECTOR ..	5
Screen and Seats	5
Using the Zoom Lens	5
Loading the Slide Tray	5
Installing the Slide Tray	6
Preparing the Projector	6
OPERATING THE PROJECTOR	7
Forward and Reverse Buttons	7
Remote Control	7
Random Projection	7
Normal Slide-Tray Removal	7
Emergency Slide-Tray Removal	7
Alternative Projection Methods	8
For Long-Run Applications	8
AFTER THE SHOWING—A SHUTDOWN PROCEDURE	8
SERVICING THE PROJECTOR	9
Projection Lamp Replacement	9
Thermal Fuses	9
Cleaning	9
AUXILIARY EQUIPMENT	10
WARRANTY	12

NOTICE: Equipment subject to minor appearance changes.

the KODAK EKTAGRAPHIC slide projector model AF-2

FEATURES—The KODAK EKTAGRAPHIC Slide Projector, Model AF-2 (Automatic Focus), has been designed for professional slide presentations. One of the valuable features of this projector is the automatic focusing device which keeps each slide in focus throughout its projection. You will find the projector to be an exceptionally durable, dependable audiovisual device—versatile, easy to operate, efficient in its functions. The features that distinguish your projector are these:

- Automatic focusing is accomplished by a built-in electronic control.
- A choice of three Kodak trays is available for use with the Model AF-2 Projector. Each tray has convenient slide identification numbers.
- The KODAK CAROUSEL* Universal Slide Tray, furnished with the projector, has an 80-slide capacity and accepts glass and cardboard slides up to $\frac{1}{8}$ inch thick. (The projector will also accommodate the KODAK CAROUSEL 80 Slide Tray and the KODAK CAROUSEL 140 Slide Tray.)
- Any transparency format in a 2 x 2-inch mount can be projected, including 126-size (26.5 x 26.5mm), 135-size (22.9 x 34.2mm), 828-size (26.2 x 38mm), 127-size (38 x 38mm), and 110-size (12 x 15.8mm) transparencies in 2 x 2-inch mounts or KODAK 2 x 2 Adapters for 110 Slides.
- A timer in the projector provides automatic changing of slides for 5-, 8-, or 15-second periods. Split-second intervals between slides eliminate long dark-screen periods.
- Slides can be projected in forward or reverse sequence or as individually selected.
- A remote control with a 12-foot cord gives forward, reverse, and focusing control away from the projector. Extension cords (see page 10) can be added if needed.
- Focus shift of the projected image is minimized because all slides are conditioned by warm air before projection.
- Precise horizontal and vertical positioning of each slide is provided. As a result, screen images from two of these projectors can be exactly superimposed. Accurate image registration depends upon carefully mounted transparencies.
- The illuminated control panel includes a 4-position Selector Switch for OFF, FAN, and LOW and HIGH light output.
- Noise is minimized by low blower speed.
- Elevation and leveling controls are provided.
- The 300-watt ELH lamp produces less heat than a 500-watt CBA lamp, but offers equivalent light output.
- A lamp ejector lever simplifies lamp replacement.
- The heat-absorbing glass and condenser lens are held in place independently of any other mechanism. This means that a new lamp can be installed without danger of accidentally displacing these optics.
- The projector is wired to accommodate the KODAK CAROUSEL Dissolve Control and other plug-in accessories (see page 10).

*All CAROUSEL equipment mentioned in this manual can be used with the KODAK EKTAGRAPHIC Slide Projector, Model AF-2.

SPECIFICATIONS

HEIGHT: 4 inches (102mm); with tray— $6\frac{1}{16}$ inches (154mm).
WIDTH: $10\frac{3}{4}$ inches (273mm). **LENGTH:** $11\frac{3}{8}$ inches (289mm). **WEIGHT:** $10\frac{1}{2}$ pounds (4.76 kg). **POWER REQUIREMENTS:** 110 to 125 volts, 60 Hz, 400 watts. **PROJECTION LAMP:** Furnished—ANSI Code ELH lamp (300-watt, 120-volt, quartz-halogen, elliptical reflector); replacement—Code ELH, ENH, or ENG lamp (see table, page 9).

AVAILABLE PROJECTION LENSES*

FLAT - FIELD LENSES: KODAK EKTANAR, $2\frac{1}{2}$ -inch (65mm) f/3.5, 3-inch (75mm) f/3.5, 4-inch (100mm) f/2.8, 5-inch (125mm) f/2.8, Zoom 4 to 6-inch (100 to 150mm) f/3.5, and KODAK EKTANON, 7-inch (180mm) f/3.5.

CURVED - FIELD LENSES:† KODAK Projection EKTANAR C, 102mm f/2.8, 127mm f/2.8, and Zoom 102 to 152mm f/3.5.

*Lenses of other focal lengths are available from commercial suppliers.
†Designed specifically to compensate for film curl in cardboard and plastic slide mounts (without cover glass); the result is improved edge-to-edge image sharpness.

the controls and their functions

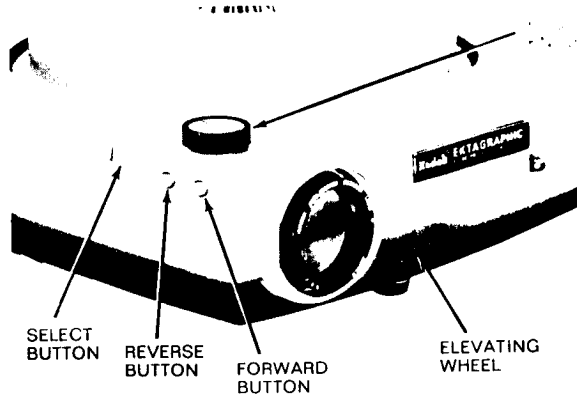

FIGURE 2

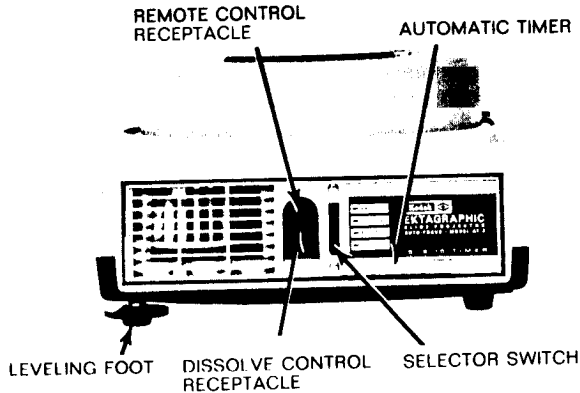

FIGURE 1

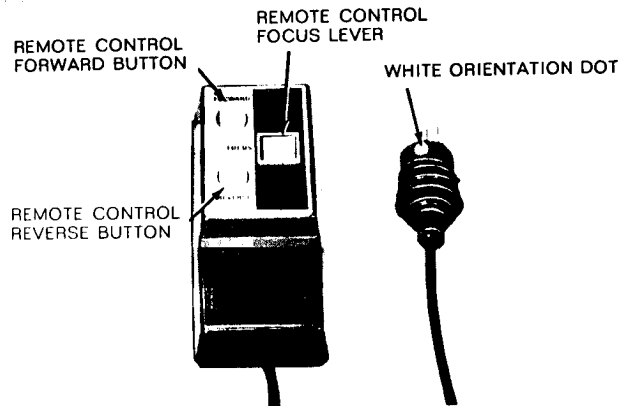

FIGURE 3

Remote Control Receptacle (Figure 1)

The 5-pin receptacle is for the connector on the remote-control cable. The connector must be oriented correctly (colored dot on the connector facing up, see Figure 3) before you insert it into the receptacle.

Dissolve Control Receptacle

Each KODAK Dissolve Control projector cord has a 7-prong connector which fits the remote control receptacle.

Selector Switch

When this switch is at FAN, the cooling fan and mechanism will operate but the projection lamp will not be lighted. This position is provided primarily to operate a dissolve control, or to cool the projector rapidly for lamp replacement. At HIGH, the ELH projection lamp provides full illumination (rated lamp life—35 hours). At LOW, 70% of full illumination is provided (average lamp life—105 hours).

Automatic Timer

The triangle on the serrated bar for the timer can be moved to any of four settings: "M" for manual control; "5," "8," or "15" for an automatic interval of 5, 8, or 15 seconds.

Focus Knob (Figure 2)

Only the first image requires focusing; the remaining images will be automatically focused. Turning the focus knob will focus the image on the screen. When intermixed glass- and board-mounted slides are projected, focus sharply on a board-mounted slide to maintain best focus. Moving the knob toward the side of the projector releases the focusing mechanism and permits quick insertion and removal of the lens. The focus knob and the focus lever on the remote

control function independently.

Forward and Reverse Buttons

These buttons are at the projector controls for forward or reverse movement of the slide tray, one slide space at a time.

Select Button

When the select button is depressed and held down, the slide tray can be rotated to select any slide for projection. Another use of this control is for the showing of single slides without a slide tray, or retrieving a slide from the gate.

Elevating Wheel

When this device is turned, it raises or lowers the front of the projector for vertical adjustment of the screen image. The range of elevation is from 0 to 6½ degrees.

Leveling Foot (Figure 1)

Turning the leveling-foot wheel raises or lowers the left side of the image on the screen.

Remote Control Forward Button (Figure 3)

Depressing the button rotates the slide tray one slide space at a time in the forward (counterclockwise) direction.

Remote Control Reverse Button

Firmly depressing the button rotates the slide tray one slide space in the reverse (clockwise) direction.

Remote Control Focus Lever

Forward and backward movement of this lever focuses the screen image. The remote focusing control will override the automatic focusing device until the lever is released, then automatic focus is reinstated.

setting up —the room and the projector

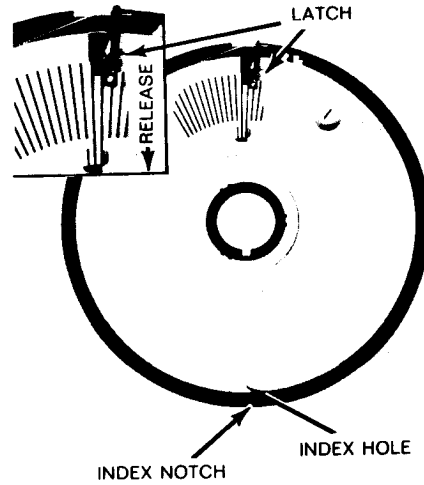

FIGURE 5

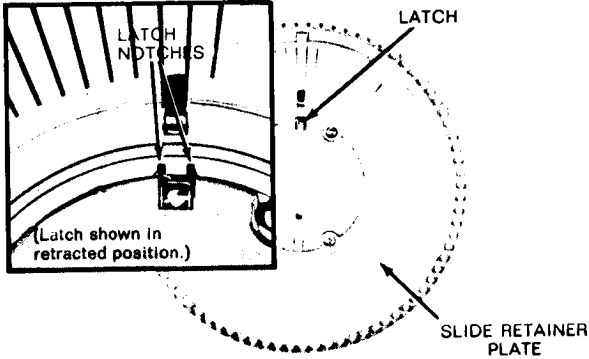

FIGURE 4

SCREEN AND SEATS

Because slides may be horizontal, vertical, or square, a square screen is most desirable. It should be large enough for easy viewing by everyone present and (for most installations) should be at the same level as, or higher than, the projector.

For best results with most slides, the rear row of seats should not be farther from the screen than eight times the projected image height. Seats should be placed as close as possible to both sides of the beam thrown by the projector. The screen image will appear most realistic to the persons seated near the projector beam.

USING THE ZOOM LENS

The KODAK EKTANAR Zoom Lens, 4 to 6-inch $f/3.5$, lets you vary the size of the projected image without moving either the projector or the screen. By this means, you can fill the screen at any normal projector-to-screen distance within the range of the lens.

To use the zoom lens—

- Focus the image on the screen by turning the focus knob.

- Rotate the lens barrel until the image fills the screen.

- Readjust the focus.

LOADING THE SLIDE TRAY

CAUTION: Do not use damaged slides (bent or torn mounts; exposed sharp glass corners or edges; loose or sticky tape). Such slides should be repaired or remounted before they are loaded into a tray. Also, the focus motor will be adversely affected if a matte-surface write-on slide or a slide mount without film is used.

Before you start to load the CAROUSEL Universal or CAROUSEL 80 Tray, check to be sure that the metal SLIDE RETAINER PLATE (Figure 4) is locked in the correct position by the LATCH. The formed end of the latch should be engaged in the two small LATCH NOTCHES. In case this is not so, turn the plate until it is locked.

Before you start to load the 140 tray, check to be sure that the INDEX HOLE (Figure 5) is opposite the INDEX NOTCH, as shown. If it is not, press the LATCH in the direction indicated by the arrow. Holding the latch in this position, turn the

PROJECTION DISTANCE TABLE FOR KODAK EKTAGRAPHIC SLIDE PROJECTORS

(Projection distances are approximate and are measured from projector gate to screen.)

LENS FOCAL LENGTH (IN INCHES)										SCREEN-IMAGE DIMENSIONS (IN INCHES)				
1.4	2	3	4	5	7	9	11	4 to 6 (Zoom)		135—35mm	126	SUPER-SLIDE	SINGLE-FRAME FILMSTRIP	110
PROJECTION DISTANCES (IN FEET)														
2	3	4	5½	7	10	12½	15½	5½ to 8½	13½ x 20	15½ sq	22 sq	10 x 13½	6½ x 8½	
3	4	6	8	10	14	18	22½	8 to 12	20 x 30	23 sq	33½ sq	15 x 20	10 x 13½	
3½	5½	8	10½	13	18½	24	29	10½ to 16	27 x 40	31 sq	44½ sq	20 x 27	14 x 18	
4½	6½	10	13	16½	23	29½	36	13 to 19½	33½ x 50	39 sq	55½ sq	26 x 33½	17½ x 23	
5½	8	11½	15½	19½	27	35	42½	15½ to 23½	40 x 60	45 sq	60 sq	30 x 40	20½ x 26½	
6½	9	14½	18	23	32½	41½	51	18½ to 27½	48 x 72	56 sq	80 sq	36 x 48	26 x 34	
8½	12	18½	24½	30½	42½	55	67	24½ to 36½	64 x 96	75 sq	87 sq	48 x 64	33 x 43½	
10½	15	23	30½	38	53	69	84	30½ to 45½	80 x 120	93 sq	132 sq	60 x 81	41½ x 54½	
12½	18	27	36½	45½	64	82	100	36½ to 55	96 x 144	112 sq	160 sq	72 x 96	49 x 64½	

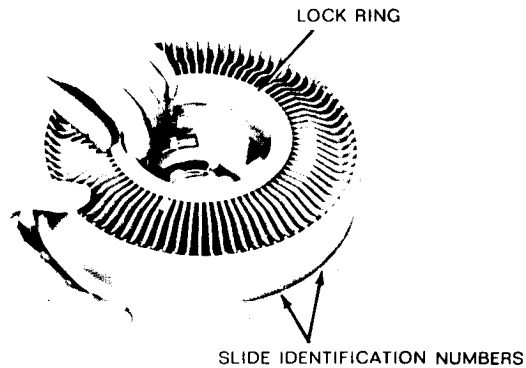

FIGURE 6

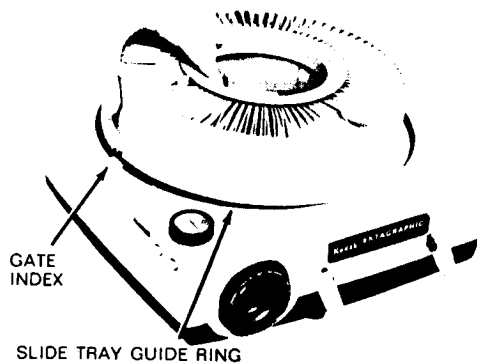

FIGURE 7

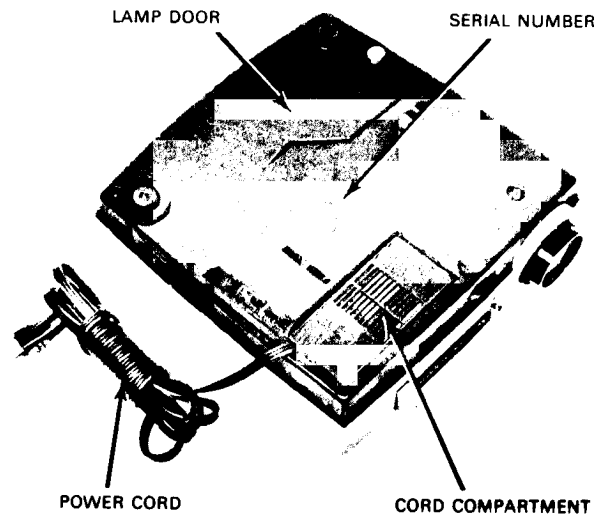

FIGURE 8

bottom plate until the index hole points to the index notch. Then release the latch.

The molded numbers on the trays are **SLIDE IDENTIFICATION NUMBERS** (Figure 6). (Only even numbers are marked on the 140 tray.) The slide being shown will be opposite the gate index on the projector.

Remove the slide **LOCK RING** (Figure 6) by turning it counterclockwise (**UNLOCK**) and lifting it off the tray. Insert a slide in each slot in the tray, orienting the slide so that the image projected on the screen is right-side up and reads correctly from left to right.

After all slides are in the tray, replace the lock ring, turning it toward **LOCK** until you feel the detent action once or twice. This will lock the ring to the tray.

INSTALLING THE SLIDE TRAY

The **CAROUSEL Universal** and **CAROUSEL 80** Trays

Hold the tray over the projector, center it over the center post on the top of the projector, and turn it to place the slide-identification number "0"—or "zero position"—at the **GATE INDEX**, as shown in Figure 7. Next, lower the tray and seat it firmly within the **SLIDE TRAY GUIDE RING**. If the tray and projector components do not mesh properly, recheck the metal slide retainer plate as described under "Loading the Slide Tray."

The **CAROUSEL 140** Tray

Put the loaded slide tray on the projector so that the hole in the center of the tray fits over the center post on the top of the projector; then revolve the tray slowly in a *clockwise direction* until the identification bar—or "zero position"—(between numbers 2 and 140) on the tray is adjacent to the

gate index. The tray will drop into operating position on the top of the projector. If the slide tray does not easily drop into place, check the alignment of the index hole and index notch as described under "Loading the Slide Tray."

NOTE: The 140 tray drops down farther during the first change cycle or when the select button is pressed.

Using an Extra Slide or Cardboard

If you wish to use an extra slide, for a total of 81 (or 141 with the 140 tray), or a title slide that will be projected as soon as the projection lamp goes on, insert this slide in the projector gate (see Figure 10) before you set the tray in place. Or, if you want the screen to be dark after you have shown slide No. 80 (or No. 140 in the 140 tray), insert a 2 x 2-inch piece of thin cardboard in the gate before you position the tray on the projector. This additional slide or piece of cardboard will enter the blocked-off space in the tray at No. 0 when the first regular slide is projected; it will return to the gate when the slide tray is positioned at zero.

Another use for the 2 x 2-inch cardboard is to separate or terminate small groups of slides in a tray. Insert a cardboard in the tray whenever you want a dark-screen interval.

PREPARING THE PROJECTOR

1. Open the door of the **CORD COMPARTMENT** (Figure 8) on the bottom of the projector. Remove the remote control cord and withdraw the **POWER CORD**.

IMPORTANT: Always make sure you have pulled out the cord to its full length before you turn on the projector. *The compartment must not be used for storage during projection.* This is necessary to provide proper air circulation through the projector case.

operating the projector

At this point the projector should have been prepared for operation as described in the previous section. Now move the selector switch to LOW or HIGH, depending on which level of illumination is best suited to your projection situation.

(If your slide show has been designed for automatic projection, set the timer at 5, 8, or 15. The slide-changing mechanism will then be actuated automatically and each slide will be shown for the number of seconds you have selected.)

FORWARD AND REVERSE BUTTONS

To project the slide with the next higher identification number, momentarily depress the *forward* button; the slide tray will rotate one slide space in the forward (counterclockwise) direction. Depress the *reverse* button to rotate the tray one slide space in the reverse (clockwise) direction. (Either button can be used to override automatic-timer operation, if desired.)

IMPORTANT: When you use the reverse button, press it *firmly*. If this button is not firmly depressed, the slide tray may rotate in a forward direction.

REMOTE CONTROL

The forward and reverse buttons on the remote control function the same as those on the projector.

The focusing lever on the remote control performs the same function as the focus knob on the projector.

RANDOM PROJECTION

To project a slide out of sequence:

1. With one hand, firmly depress the select button and hold it down.
2. Rotate the slide tray with the other hand until the number of the slide you want to project is opposite the gate index on the projector.
3. Release the select button. The selected slide will be immediately projected.

NORMAL SLIDE-TRAY REMOVAL

If the zero position is at the gate index, simply lift off the tray. Otherwise:

1. *With the projector turned on*, depress the select button firmly and hold it down.
2. Rotate the slide tray—in either direction—until the zero position is opposite the gate index.
3. Release the select button and lift off the tray.

EMERGENCY SLIDE-TRAY REMOVAL

In the event that the slide-changing mechanism becomes inoperative as the result of a defective slide becoming lodged in the projector gate, the tray usually will need to be removed in order to eliminate the trouble. If the tray does not advance, depress either the forward or reverse button. If this does not free the stuck slide, follow the tray-removal procedure given on the next page.

The power cord, permanently attached to the projector, has a 3-prong polarized plug for connection to a 110 to 125-volt, 60 Hz outlet of the grounding type.

Connect the remote control cord to the projector with the all ORIENTATION DOT (Figure 3) on the cord plug facing up.

NOTE: The white dot on the plug of the remote control assembly for your projector denotes a 5-conductor cord. This assembly, or an exact duplicate, must be used with the Model AF-2 Projector for all applications, including installations where one or more KODAK Remote Extension Cords are employed.

3. If a loaded slide tray is not on the projector, install one at this time. Use the procedure described above.
4. Set the automatic timer at M. Move the selector switch to either LOW or HIGH.
5. If you have placed an additional slide in the projector gate, as described on page 6, this slide will now be projected on the screen. If you have placed a square of cardboard in the gate, the screen will be dark. Otherwise, the screen will be bright. If there is no image, momentarily depress the *forward* button on the projector or the remote control to project the first slide.
6. Focus the image on the screen, using the focus knob or the remote-control focus lever. Only the first image requires focusing; the remaining images will be automatically focused. (See page 5 for focusing instructions for the zoom lens.)
7. Center the image vertically on the screen (elevating dial).
8. Level the screen image (leveling foot).
9. Move the selector to OFF until you are ready to start projecting.

servicing the projector

Before you attempt any maintenance or cleaning operation on the projector, make certain the unit is cool. *Disconnect the power cord from its outlet.* Also, it is a good idea to remove the slide tray and the remote control cord.

PROJECTION LAMP REPLACEMENT

Turn the projector upside down. Open the LAMP DOOR (Figure 8) by turning the coin-slotted screw counterclockwise.

Release the LAMP EJECTOR LEVER (Figure 11) from the notch in which it is secured, and lift the lever to eject the lamp from its socket. Withdraw the lamp, noting how the two pins on its base fit into the socket.

To install a lamp, place it on the socket with the two pins on its base fitting in the two slots in the socket. Return the ejector lever to its original position and make sure it is latched; the lever will locate the lamp correctly for operation. Close and fasten the lamp door.

The standard replacement lamp for this projector is a 300-watt, 120-volt ANSI Code ELH lamp; however, lamps with differing specifications may be desirable for some applications. See table below.

PROJECTION LAMPS FOR KODAK EKTAGRAPHIC SLIDE PROJECTORS

ANSI Code	Relative Brightness		Average Life (Hours)
ELH (medium brightness/life)	LOW	70	105
	HIGH	100	35
H (maximum lamp economy)	LOW	50	525
	HIGH	75	175
ENG* (high brightness)	LOW	85	45
	HIGH	130	15

*Continual use of high-brightness lamps may shorten useful slide life.

THERMAL FUSES

Your projector is equipped with thermal fuses to prevent overheating. Should the fuses open, the projector will not operate. Replacement of the fuses demands partial disassembly of the projector, a job requiring factory or repair station attention. (See listing of Kodak service facilities on page 12.) Also, you should determine and correct, if possible, any situation outside the projector that may have contributed to fuse failure—inadequate ventilation, dusty environment, etc.—before using the projector.

CLEANING

The optical system of your projector must be kept clean for best results. Fingerprints or smudges on the lenses will reduce the brightness and clarity of the screen image. A small amount of dust will have a negligible effect on the projected images.

Projection Lens

Remove the lens from the projector. With a soft, clean, lintless cloth or Kodak Lens Cleaning Paper, wipe the front and back surfaces of the lens.

Replace the lens, making sure that the teeth on the lens are engaged by the gear on the focus-knob shaft.

Condenser Optics

WARNING: Heat-absorbing glass is subjected to special

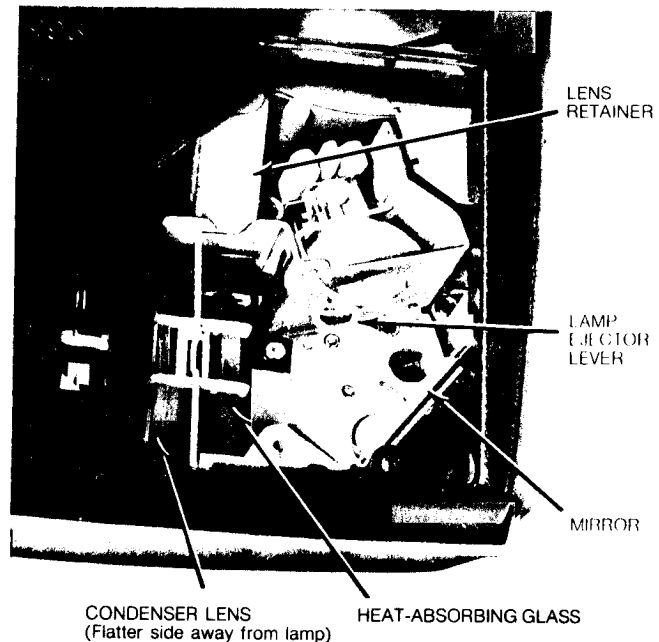

FIGURE 11

processes that tend to put stresses and strains into it. Consequently, the glass may shatter for no apparent reason and without warning. Therefore, handle heat-absorbing glass with care and follow these recommendations:

1. For personal safety, use a piece of cloth or a glove while handling the glass.
2. Place the glass on an insulating material such as wood, rubber, or cardboard.
3. Keep the glass covered while it is removed so that if shattering occurs, it will be confined.

Turn the projector upside down. Open the lamp door as described above. Release the LENS RETAINER from the notch in which it is secured and raise it to an upright position. Carefully lift out the HEAT-ABSORBING GLASS and the CONDENSER LENS, noting their positions in the chamber. Do not attempt to remove the MIRROR; it has been precisely aligned during manufacture to provide optimum screen illumination. Avoid touching the mirror surface with the fingers. Clean the mirror and both sides of the heat-absorbing glass and condenser lens with a clean, soft, lintless cloth or with KODAK Lens Cleaning Paper.

Replace the elements as follows, holding each one by its edges to prevent finger marks: condenser lens in the guides nearer the front of the projector with the flatter side of the condenser toward the front; heat-absorbing glass in the guides nearer the mirror. Return the lens retainer to its original position and make sure it is latched.

NOTE: Failure to position the condenser lens correctly will cause the focus motor to run continuously.

Close and fasten the lamp door.

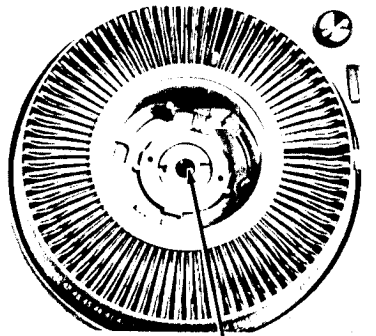

TRAY REMOVAL SCREW

FIGURE 9



FIGURE 10

Proceed as follows:

1. Turn the coin-slotted TRAY REMOVAL SCREW (Figure 9) in either direction as far as it will go.
2. While holding the screw in this position, lift the tray off the projector.
3. Remove the obstruction from the projector gate by depressing the select button, or correct any other cause of the malfunction.
4. With the locking ring in place, turn the tray upside down. Rotate the bottom plate, or slide retainer, until the latch engages the notches in the plate (or until the index hole is adjacent to the index notch on the 140 tray). See page 5. Place the tray on the projector. Repair the damaged slide (if this was the cause) and return it to the tray.

ALTERNATIVE PROJECTION METHODS

1. *Slides in tray without tray ring:* By leaving the tray ring off, slides can be inserted or removed easily. This simplifies editing.
2. *With the KODAK CAROUSEL Stack Loader:* Lets you project and edit up to 40 2 x 2-inch slides in cardboard or thin plastic mounts (.040 to .060-inch thick) without using a slide tray.
3. *Without a slide tray:* A single slide can be shown simply by inserting it, correctly oriented, into the projector gate as shown in Figure 10. To remove the slide, depress the select button.

FOR LONG-RUN APPLICATIONS

If the projector is to be run for an unusually long period of time, these precautions should be observed:

- Provide for unrestricted flow of air to and from the openings in the projector housing. If the projector is to be used in a window display or in a cabinet, provide a duct for warm air expelled from the rear grill vent. In some cases, additional forced air ventilation may be needed.
- Keep air circulating through the projector. Air at normal room temperature is satisfactory.

In normal use, the parts of the projector that are subject to wear have about equal life expectancy; therefore, no other special precautions are necessary. However, in some specialized applications, a projector may be cycled forward rapidly for hundreds of hours. Under these circumstances, you should consider making the modifications recommended in Kodak Pamphlet No. S-70-2-1, *Extending Clutch Life for Heavily Used KODAK Slide Projectors*. You can obtain a

copy by writing to the address below.

Additional information on long-run applications is contained in Kodak Pamphlets No. S-53, *Heavy-Duty Operation of KODAK EKTAGRAPHIC and CAROUSEL Slide Projectors*, and No. S-56, *The Care and Maintenance of KODAK CAROUSEL Slide Trays*. A single copy of each is available on request from Eastman Kodak Company, Dept. 412L, Rochester, N. Y. 14650. Also ask for a free copy of *Index to Kodak Information (L-5)*, which lists many other Kodak publications.

after the showing —a shutdown procedure

We recommend that you use a standard shutdown procedure after your slide presentation has been completed. This will help provide proper care of the projector and will make certain it is ready for the next user.

1. Rotate the slide tray to the zero position, using the select button (page 7, **RANDOM PROJECTION**).
2. Move the power switch to OFF. Rapidly cooling the projector after each use is not recommended. But, if the unit must be handled immediately after a slide presentation or the lamp must be changed quickly, the fan can be run to accelerate cooling of the projector. (The right-rear corner of your projector may be uncomfortably warm for several minutes after you switch off the power. The maximum temperature reached, however, will be well below the danger point for the lamp, projector, tray, or slides.)
3. Remove the slide tray from the projector.
4. Retract the elevating and leveling feet.
5. Retract the lens (focus knob).
6. Disconnect the remote-control and power-cord plugs. Store the cords in the cord compartment.

If there is no need to move the equipment before your next slide presentation, you can omit steps 4 through 6.

Each of the items described below is a useful accessory for the KODAK EKTAGRAPHIC Slide Projector, Model AF-2.



KODAK CAROUSEL
Universal Slide Tray

KODAK CAROUSEL 80
Slide Tray



KODAK CAROUSEL 140
Slide Tray



Additional slide trays, supplied in attractive bookshelf-type storage boxes. Each box contains an identification card and tray sticker. Use the CAROUSEL Universal Slide Tray for all slides, including glass-mounted slides up to 1/8 inch thick; use the CAROUSEL 80 Slide Tray for slides mounted in cardboard or thin glass (up to 1/10 inch thick). For 140-slide capacity of slides in cardboard or thin plastic mounts up to 1/16 inch thick, use the CAROUSEL 140 Slide Tray.



KODAK CAROUSEL
Projector Case,
Model B

Accommodates projector, one slide tray, extra lenses, cords, and spare lamp. Made of gray, heavy-duty simulated leather. Provides complete protection plus convenience and attractive appearance during transportation and storage. (Will hold the KODAK EKTAGRAPHIC Slide Projector, Model AF-2, with 7-inch or zoom lens in place if the projector is inserted on its side.)



KODAK Carrying Case
for KODAK
CAROUSEL
Slide Trays

Has two compartments so that three slide trays can be carried or one or two trays plus extension cords, lenses, and other equipment.

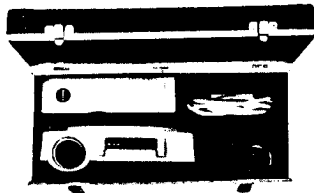

KODAK
AV Compartment
Case

A convenient, rugged case of vulcanized fiber. Will accommodate the KODAK EKTAGRAPHIC Slide Projector, Model AF-2, with 7-inch or zoom lens in place. Also will hold one slide tray, extra lenses, cords, and spare projection lamp.

auxiliary equipment



KODAK
Projection Lenses

Several KODAK Projection Lenses are available for your projector. See table on page 3.



KODAK Remote
Extension
Cord, 25-Foot

Extends the range of the 12-foot remote control cord so that you can operate the projector from a location near the screen. Several extension cords can be added to accommodate any reasonable projection distance.



KODAK CAROUSEL
Dissolve Control, Model 2

Controls two Model AF-2 projectors for slide shows in which one image "dissolves" into the next while screen illumination remains virtually constant. The unit contains a timer for continuous automatic operation, or it can be controlled by the remote control cord of one of the projectors. Can also be controlled by the KODAK CAROUSEL Sound Synchronizer, Model 2. Ideal for sales presentations or more sophisticated slide showings.



KODAK CAROUSEL
Sound Synchronizer, Model 2

This unit permits a stereo record/playback tape recorder, that is equipped with an external speaker jack, to be used as a programmer with your projector. In operation, one of the tape tracks is used for slide-change signals while all other sound is recorded on the other channel. Can also control two projectors through a KODAK CAROUSEL Dissolve Control.

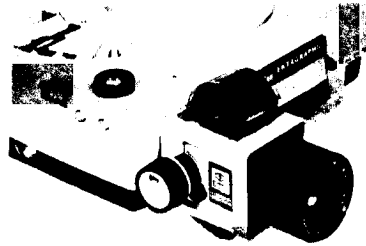

KODAK EKTAGRAPHIC Filmstrip Adapter

The KODAK EKTAGRAPHIC Filmstrip Adapter* will enhance the versatility of your EKTAGRAPHIC Slide Projector, Model AF-2, by equipping it for the projection of 35mm single-frame filmstrips.

*For more even screen illumination when using the filmstrip adapter with this projector, it is recommended that the CONDENSER LENS (Figure 11) be replaced with Kodak Part No. 625889. (Utilization of this substitute condenser lens with slides will result in a slight decrease in the projector's light output.) See your supplier of Kodak audiovisual products or write to Eastman Kodak Company, Dept. 641, Rochester, N. Y. 14650.

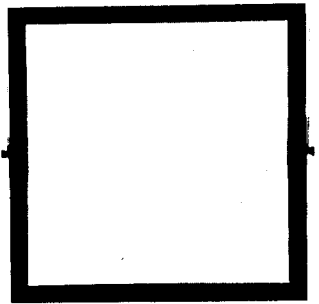

KODAK EKTALITE Projection Screen, Model 3 (40x40)

Provides a uniformly brilliant image that almost totally rejects stray light falling on the screen from anywhere outside the normal viewing position. The result—excellent contrast and color saturation, even in brightly lighted areas.

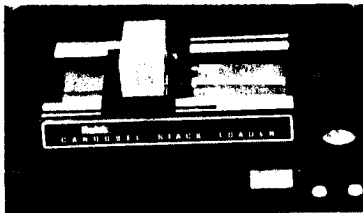

KODAK CAROUSEL Stack Loader

Lets you project and/or edit up to forty 2 x 2-inch slides in cardboard or thin plastic mounts without placing them in a slide tray. Uses the gravity-feed system that makes your projector so reliable.

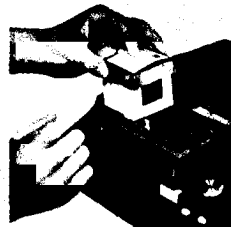

KODAK Slide Clip (for KODAK CAROUSEL Stack Loader)

The Kodak Slide Clip provides a new concept that makes handling and showing "blocks" of 2 x 2-inch slides easy and convenient. It helps to prevent loose slides from being accidentally dropped—and the 12-clip box gives them compact, low-cost storage.

SERIAL NUMBER

Each KODAK EKTAGRAPHIC Slide Projector, Model AF-2, has a serial number stamped on the bottom of the projector near the cord compartment. Make a note of this number for your records in case your projector is lost or stolen.

warranty

KODAK EKTAGRAPHIC Slide Projector, Model AF-2

Carefully follow all the instructions in this manual to get the best results and to prevent damage to your projector.

Your projector will be repaired at no charge within one year after purchase, except for worn-out projection lamps and damage caused by misuse or circumstances beyond Kodak's control. This warranty applies only to the projector, and Kodak cannot be responsible for other losses or damages of any kind resulting from projector failure.

Except as mentioned above, no other warranty, express or implied, applies to this slide projector.

For service during or after the warranty period, you may take your projector to a Kodak Consumer Center (located in many U.S. cities). Please consult your local telephone directory under Photographic Equipment and Supplies for the locations of these centers. You may also return the projector directly or through a dealer in Kodak audiovisual products to one of the following Kodak Equipment Service Centers. To help us get the projector back to you promptly, please enclose a note giving the details of the projector malfunction and date of purchase.

Eastman Kodak Company
Central Equipment Service Center
800 Lee Road
Rochester, N. Y. 14650

Eastman Kodak Company
Regional Equipment Service Center
5315 Peachtree Industrial Blvd.
Chamblee, Ga. 30341

Eastman Kodak Company
Regional Equipment Service Center
2800 Forest La.
Dallas, Tex. 75234

Eastman Kodak Company
Regional Equipment Service Center
12100 Rivera Rd.
Whittier, Calif. 90606

Eastman Kodak Company
Regional Equipment Service Center
1334 York Ave.
New York, N. Y. 10021

Eastman Kodak Company
Regional Equipment Service Center
1901 West 22nd St.
Oak Brook, Ill. 60521

Eastman Kodak Company
Regional Equipment Service Center
9100 Alcosta Blvd.
San Ramon, Calif. 94583

Eastman Kodak Company
Regional Equipment Service Center
1122 Mapunapuna St.
Honolulu, Hawaii 96819

Service is also available through dealers selling Kodak audiovisual products. Refer to the yellow pages of your telephone directory under Audiovisual Equipment and Supplies.

Kodak, Ektagraphic, Carousel, Ektanar,
Ektanon, and Ektalite are trademarks.



MOTION PICTURE AND AUDIOVISUAL MARKETS DIVISION
Rochester, N. Y. 14650



Basic Operating Instructions

KODAK EKTAGRAPHIC Slide Projector, Model AF-2

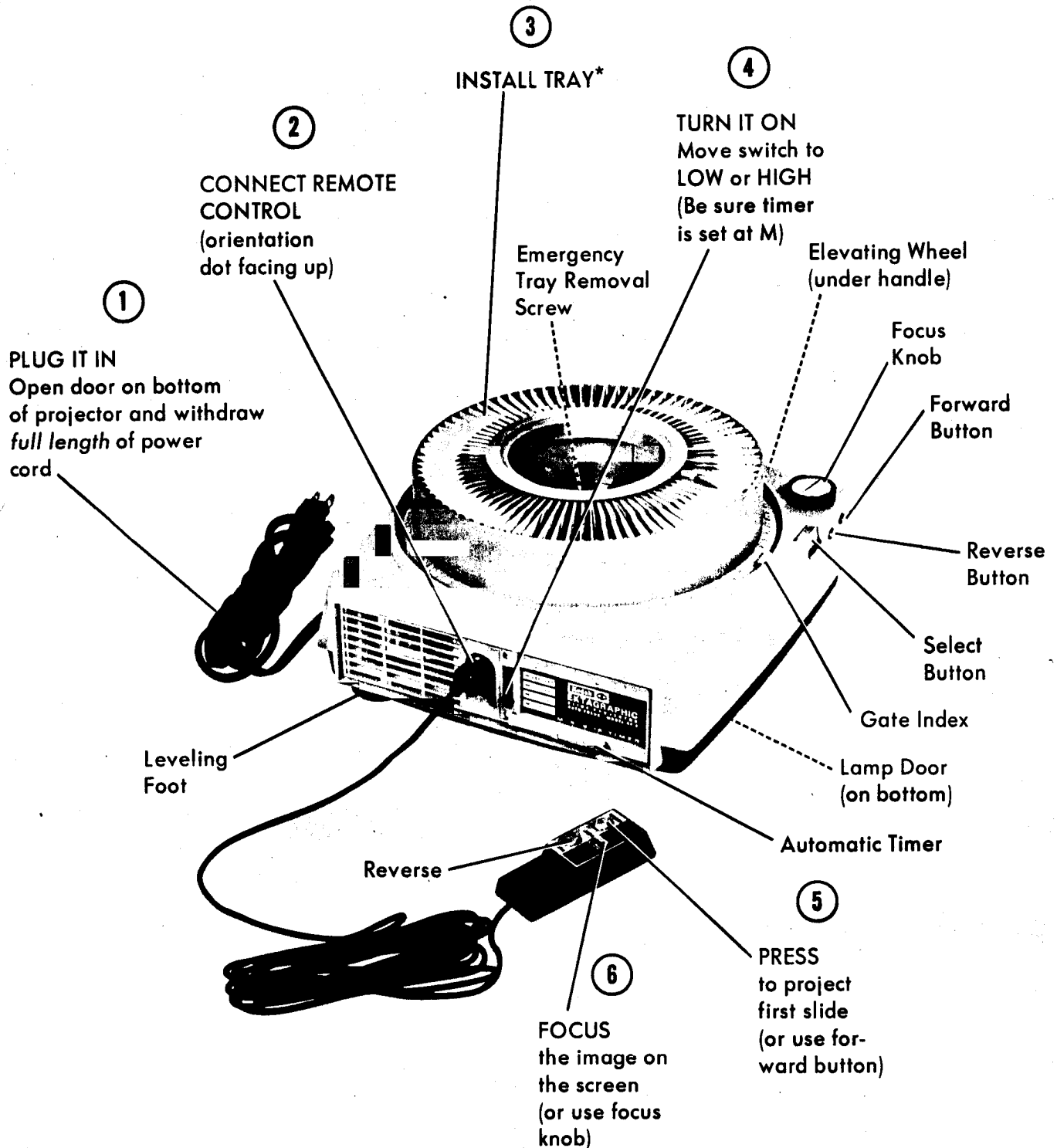

*Position tray with zero (0) at gate index.

(See other side)

ELEVATING WHEEL. To raise or lower the image on the screen, turn the elevating wheel on the front of the projector.

LEVELING-FOOT WHEEL. To raise or lower the left side of the image on the screen, turn the leveling-foot wheel.

REMOTE CONTROL (Timer set at M). To project the slide with the next higher identification number, momentarily depress the *forward* button; to rotate the tray one slide space in the reverse (clockwise) direction, depress and release the *reverse* button. (Press the reverse button firmly; if this button is pressed too lightly, the tray may rotate in a forward direction.) To focus the image on the screen, use the focus lever.

These functions can also be accomplished by operating the forward button, the reverse button, and the focus knob on the projector body.

RANDOM PROJECTION (Timer set at M). To project a slide out of sequence:

1. Firmly depress the select button and hold it down.
2. Rotate the slide tray until the slide you want to project is opposite the gate index on the projector.
3. Release the select button. The selected slide will be immediately projected.

AUTOMATIC TIMER. For automatic advance of slides at intervals of 5, 8, or 15 seconds, set the timer at "5", "8", or "15" respectively.

SLIDE-TRAY REMOVAL. If the zero position on the tray is opposite the gate index, simply lift off the tray. Otherwise:

1. With the projector turned on, depress the select button firmly and hold it down.
2. Rotate the slide tray—in either direction—until the zero position is opposite the gate index.
3. Release the select button and then lift off the tray.

EMERGENCY SLIDE-TRAY REMOVAL. If for any reason it becomes necessary to remove the tray without returning it to the zero position, use this procedure:

1. Turn the coin-slotted tray removal screw in either direction as far as it will go.
2. Hold the screw in this position and lift off the tray.
3. Turn the tray upside down and rotate the bottom plate until it locks.

PROJECTION LAMP REPLACEMENT. If the lamp burns out during a showing:

1. Allow the fan to run to cool the lamp and lamp compartment.
2. Remove the slide tray.
3. Move the switch to OFF.
4. Disconnect the power cord.
5. Turn the projector upside down.
6. Open the lamp door by turning the coin-slotted screw counterclockwise.
7. Release the lamp ejector lever from the notch in which it is secured. Lift the lever to eject the lamp. Withdraw the lamp.
8. Place a new lamp (ANSI Code ELH) in the socket with the two pins on its base fitting the two slots in the socket. (Code ENH lamp can be used for extended lamp life with less output; ENG lamp for more brightness, but shorter life.)
9. Return the ejector lever to its original position and make sure it is latched. The lever will locate the lamp correctly for operation.
10. Close and fasten the lamp door.

For more detailed information, refer to the instruction manual.

Kodak and Ektagraphic are trademarks.

Motion Picture and Audiovisual Markets Division

EASTMAN KODAK COMPANY • ROCHESTER, N.Y. 14650

ANGSTROM STAGE LIGHTING, INC.

FAX TRANSMITTAL

DELIVER TO:

FAX NUMBER: 505-473-0614
NAME: Bruce Hamilton
COMPANY:
DATE: Thursday, January 4, 1996
TIME: 9:50 AM

SENT FROM:

NAME: JUAN CORDOBA

MESSAGE/COMMENTS:

Bruce,
 Here are the specifications on the LD-360M Dimmer packs.
 The sale price for the LD-360M is \$595.00 plus tax.
 Delivery is about one week. Please, call me if you have any
 questions.
 Thanks

Juan

TREE MOUNT DIMMERS

Take a look in our tree-mount dimmer packs! You will find features which are not found in any other tree-mount dimmers. Engineering excellence and concern for quality are visible throughout. We use dual SCR's for unsurpassed reliability. Full magnetic circuit breakers protect electronic components in the event of overloads or short circuits. There are no fuses to replace. All components are on a G-10 FR circuit board, with minimum wiring for rugged durability and ease of service. You will also find professional quality line noise filtering that eliminates buzz and interference with sensitive audio equipment.

GENERAL SPECIFICATIONS

LOAD POWER CAPACITY. Any channel may handle up to 2400 watts, but the total power of all the loads on a pack should not exceed the pack's power input.

OUTPUT CIRCUITS. The LD-360 series dimmers have six parallel blade U-ground duplex receptacles, while the LD-340 features four parallel blade U-ground duplex receptacles.

POWER DEVICES. Two 25 Amp SCR's per channel, optically isolated from control input circuitry.

CIRCUIT PROTECTION. A single illuminated magnetic circuit breaker (dual for HP models) on the power input provides fast protection from shorts and overloads. No fuses are used in power circuits.

MOUNTING. Dimmer may be mounted by a pipe clamp or bolt with the yoke provided, or may be bolted directly to a truss.

FILTERING. The rise time of the load current measured from 10% to 90% of peak current at 90 degrees conduction angle with full rated load is 250 μ S.

(Note: all specifications +/- 10% unless otherwise noted.)

LD-360M CONTROL SPECIFICATIONS

MIDI CONTROL SIGNAL. The LD-360M and LD-360M-HP utilize the MIDI communication protocol to receive control information from the LM-850 control console. The MIDI protocol provides the benefits of a "true" digital signal and is not to be confused with analog multiplexed signals. As a control signal, MIDI is a very quick and versatile protocol which can efficiently carry control information for as many as 104 dimmer channels and can be transmitted reliably over hundreds of feet.

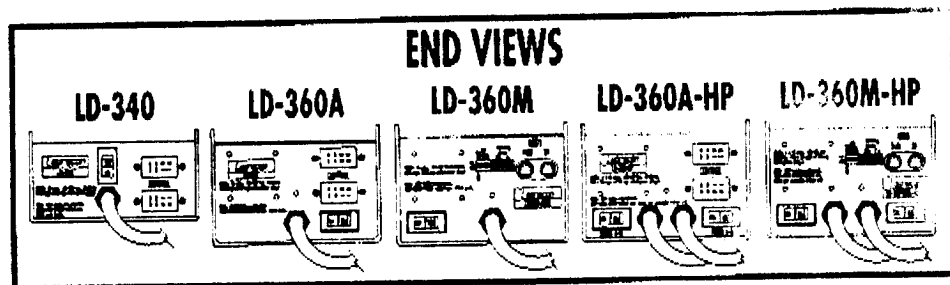

MIDI CONTROL CONNECTOR. One 5 pin female DIN connector In and one female 5 pin DIN connector Thru for daisy chaining dimmer packs.

MIDI CHANNEL. Selectable 1-16 or OMNI. Dimmer pack starting address selectable, channel 0-99.

STAND ALONE MIDI OPERATION. The LD-360M and LD-360M-HP dimmer packs respond to MIDI note-on/note-off and continuous controller information making it possible to control the dimmers with a MIDI key-board, drum machine or sequencer as well as an LM-850 control console.

ANALOG CONTROL SPECIFICATIONS

ANALOG CONTROL INPUT. 0-10VDC, 200k ohm input impedance, with input common floating. Compatible with any controller having 0-10 VDC control outputs.

ANALOG CONTROL INPUT CONNECTOR. One each male and female 8 pin Jones type with a female mating cable connector supplied with dimmer pack.

LD-340, LD-360A, LD-360M POWER REQUIREMENTS

POWER INPUT (HP specifications in parenthesis). 105-125 VAC 50-60HZ 15 Amperes (2 x 105-125VAC). 1800 (3600) watts maximum total load. Standard male

parallel blade U-ground mounted at the end of 12 gauge-3 conductor power cord(s). This standard plug(s) is rated for 15 amps maximum.

INCREASED POWER (HP Models). The LD-340, LD-360A, and the LD-360M can handle 2400 (4800) watts total pack power if the parallel blade U-ground power plug(s) is replaced with a plug rated to handle 20 amps safely, and the pack is connected to a suitable outlet(s). We recommend a 20 amp stage pin plug or a NEMA type 5-20P or L5-20P plug.

FULL ONE YEAR WARRANTY

For a period of one year from the date of sale, CAE, Inc. will replace any defective parts and will repair any defective module returned to the factory prepaid, without charge for parts or labor. Please consult your dealer for full warranty details.

CAE
TEPRLCOH
PRO LIGHTING
EQUIPMENT

10087 Industrial
P.O. Box 430
Hamburg, MI 48139
(810) 231-9373
FAX (810) 231-1631

Before 12-1-93 Dial 1-800-



FAX Transmission

10087 Industrial Dr., P.O. Box 430, Hamburg, MI 48139 USA

There are _____ pages total including this cover sheet.

To: Wody Vasulka

At: _____

From: Fred Mikeska

At CAE, Incorporated 810-231-9373 FAX 810-231-1631

Manufacturers of: Leprocon® Pro Lighting Equipment, Littlite® Gooseneck Lamps & Accessories and ISYS™ Lighting

Message:

LEPRICON?

RE: Fax info LD-360M. (\$595)

THEY ALSO MAKE

ANG 50R

MIDI COATROVERS → 48

*OUTPUTS
L157*

*0-10 VDC
\$ 795*

OUTBEAM-

Sound

1800 W

3600

*\$ 480
\$ 595*

\$ 695

DEVICE BEAM TRICE

M. 01

2000 W

TREE MOUNT DIMMERS

Take a look in our tree-mount dimmer packs! You will find features which are not found in any other tree-mount dimmers. Engineering excellence and concern for quality are visible throughout. We use dual SCR's for unsurpassed reliability. Full magnetic circuit breakers protect electronic components in the event of overloads or short circuits. There are no fuses to replace. All components are on a G-10 FR circuit board, with minimum wiring for rugged durability and ease of service. You will also find professional quality line noise filtering that eliminates buzz and interference with sensitive audio equipment.

VAVUM 2/1

GENERAL SPECIFICATIONS

LOAD POWER CAPACITY. Any channel may handle up to 2400 watts, but the total power of all the loads on a pack should not exceed the pack's power input.

OUTPUT CIRCUITS. The LD-360 series dimmers have six parallel blade U-ground duplex receptacles, while the LD-340 features four parallel blade U-ground duplex receptacles.

POWER DEVICES. Two 25 Amp SCR's per channel, optically isolated from control input circuitry.

CIRCUIT PROTECTION. A single illuminated magnetic circuit breaker (dual for HP models) on the power input provides fast protection from shorts and overloads. No fuses are used in power circuits.

MOUNTING. Dimmer may be mounted by a pipe clamp or bolt with the yoke provided, or may be bolted directly to a truss.

FILTERING. The rise time of the load current measured from 10% to 90% of peak current at 90 degrees conduction angle with full rated load is 250 μ S.

(Note: all specifications +/- 10% unless otherwise noted.)

LD-360M CONTROL SPECIFICATIONS

MIDI CONTROL SIGNAL. The LD-360M and LD-360M-HP utilize the MIDI communication protocol to receive control information from the LM-850 control console. The MIDI protocol provides the benefits of a "true" digital signal and is not to be confused with analog multiplexed signals. As a control signal, MIDI is a very quick and versatile protocol which can efficiently carry control information for as many as 104 dimmer channels and can be transmitted reliably over hundreds of feet.

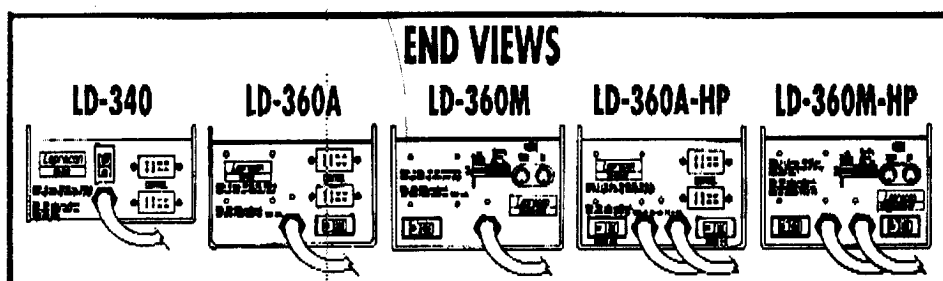

MIDI CONTROL CONNECTOR. One 5 pin female DIN connector In and one female 5 pin DIN connector Thru for daisy chaining dimmer packs.

MIDI CHANNEL. Selectable 1-16 or OMNI. Dimmer pack starting address selectable, channel 0-99.

STAND ALONE MIDI OPERATION. The LD-360M and LD-360M-HP dimmer packs respond to MIDI note-on/note-off and continuous controller information making it possible to control the dimmers with a MIDI key-board, drum machine or sequencer as well as an LM-850 control console.

ANALOG CONTROL SPECIFICATIONS

ANALOG CONTROL INPUT. 0-10VDC, 200k ohm input impedance, with input common floating. Compatible with any controller having 0-10 VDC control outputs.

ANALOG CONTROL INPUT CONNECTOR. One each male and female 8 pin Jones type with a female mating cable connector supplied with dimmer pack.

LD-340, LD-360A, LD-360M

POWER REQUIREMENTS

POWER INPUT (HP specifications in parenthesis). 105-125 VAC 50-60HZ 15 Amperes (2 x 105-125VAC). 1800 (3600) watts maximum total load. Standard male

parallel blade U-ground mounted at the end of 12 gauge-3 conductor power cord(s). This standard plug(s) is rated for 15 amps maximum.

INCREASED POWER (HP Models).

The LD-340, LD-360A, and the LD-360M can handle 2400 (4800) watts total pack power if the parallel blade U-ground power plug(s) is replaced with a plug rated to handle 20 amps safely, and the pack is connected to a suitable outlet(s). We recommend a 20 amp stage pin plug or a NEMA type 5-20P or L5-20P plug.

FULL ONE YEAR WARRANTY

For a period of one year from the date of sale, CAE, Inc. will replace any defective parts and will repair any defective module returned to the factory prepaid, without charge for parts or labor. Please consult your dealer for full warranty details.

CAE
LEPRELCOU
PRO LIGHTING
EQUIPMENT

10087 Industrial Drive
P.O. Box 430
Hamburg, MI 48139
(313) 231-9373
FAX (313) 231-1631

MIDI Implementation

Normal Control

The dimmer output channels can be controlled by any one of the MIDI continuous controllers 00 through 120. The LM-850 console will control the dimmers using exclusively MIDI continuous controllers 00 through 107, allowing each channel to be set at any of 128 discrete levels from light off (0) to full on (127).

Stand Alone Operation

The MIDI dimmer will also respond to MIDI note ON, MIDI note OFF, and velocity messages. While those commands are not usually generated by the console, they allow for controlling the dimmer directly from standard MIDI controllers such as keyboards, sequencers, MIDI percussion, or drum machines. When used in this fashion, a dimmer is turned on by MIDI note ON message. The note number determines which dimmer is addressed according to the starting address switch (If the address switch is set at 11, the 1st dimmer in the pack will respond to note 11, the 2nd dimmer will respond to note 12 etc..). The "velocity" value of the note ON sets the brightness of the light. A dimmer remains on until turned off by a note OFF message.

Even for a very short note ON note OFF sequence, a dimmer will turn on for at least 200 ms. This will allow drum machines or MIDI percussion systems to produce perceivable flashes of light. Even in this stand alone application, the MIDI dimmer will still respond to MIDI continuous controller commands having the same number as the dimmer identity number.

MIDI Channel

MIDI channel 1-16 and OMNI on-off can be set by dip switch..see previous description. Since too much data can slow down MIDI system response time, it is advisable to run a separate MIDI circuit for the lighting system, which will carry only lighting data. The synthesizers, etc. would be on other MIDI circuits, so their response time would be unaffected by demands for lighting data transmission. Most systems should therefore be run in channel 1, OMNI ON.

Playing Sequenced Cues Without the LM-850

For specific applications, it is possible to use the LM-850 to program a show where the console would not be used at all for playback, if MIDI dimmers are being used. The dimmers can be plugged into the MIDI Out from the sequencer just as the LM-850 normally would, and they will respond to the data as if the console were in place. This method can be used for setups where minimal equipment is desired, but it does have some limitations. First of all, it leaves no margin for changing the show in any way, without connecting in the LM-850 once again. Secondly, it leaves no way to manually bring up any lights if this becomes necessary (other than by controlling them, say, with a keyboard driving the dimmers). It also requires lots of MIDI data which may slow down complex shows.

The gist of this technique is that the show is recorded from the LM-850, and the sequencer is fed from the MIDI Dimmer Out rather than from the System Out. Anything that the console does-scene changes, chases, etc.,-will be recorded by the sequencer. The console can send out this data in either CONTInuous controller or NOTE mode. Again, the former is the most efficient. Be sure that on playback, the dimmers are set to the same MIDI channel that the sequencer data was recorded on. The sequencer then mimics the LM-850's output, driving the dimmers directly-and the 850 is not needed unless real time intervention is required.

Dimmer Control Assignment

The LD-360M and LD-360M-HP MIDI dimmer packs have 6 dimmer circuits built-in. Each dimmer pack has a MIDI input and MIDI thru connector. Each pack also has an identity number assignment switch. This switch is used to assign a Starting Address to each dimmer pack from 00 to 99. If a 6 channel dimmer pack is assigned the starting address 10, the 1st dimmer in the pack will respond as dimmer channel 10, the 2nd dimmer as number 11, the 3rd as number 12 etc. Its address range will be

0-137	Channel 13 label	13	13
0-138	Channel 14 label	14	14
0-139	Channel 15 label	15	15
0-140	Channel 16 label	16	16
0-141	Channel 17 label	17	17
0-142	Channel 18 label	18	18
0-143	Channel 19 label	19	19
0-144	Channel 20 label	20	20
0-145	Channel 21 label	21	21
0-146	Channel 22 label	22	22
0-147	Channel 23 label	23	23
0-148	Channel 24 label	24	24
0-149	Channel 25 label	25	25
0-150	Channel 26 label	26	26
0-151	Channel 27 label	27	27
0-152	Channel 28 label	28	28
0-153	Channel 29 label	29	29
0-154	Channel 30 label	30	30
0-155	Channel 31 label	31	31
0-156	Channel 32 label	32	32
0-157	Channel 33 label	33	33
0-158	Channel 34 label	34	34
0-159	Channel 35 label	35	35
0-160	Channel 36 label	36	36
0-161	Channel 37 label	37	37
0-162	Channel 38 label	38	38
0-163	Channel 39 label	39	39
0-164	Channel 40 label	40	40
0-165	Channel 41 label	41	41
0-166	Channel 42 label	42	42
0-167	Channel 43 label	43	43
0-168	Channel 44 label	44	44
0-169	Channel 45 label	45	45
0-170	Channel 46 label	46	46
0-171	Channel 47 label	47	47
0-172	Channel 48 label	48	48
0-173	Channel 49 label	49	49
0-174	Channel 50 label	50	50

APPENDIX 1 (CONTINUED)

Controller No.		LM-850 Function	Possible Values(Decimal)
(Decimal)	(Hex)		
50	32	Channel 51 fader	0-127
51	33	Channel 52 fader	0-127
52	34	Channel 53 fader	0-127
53	35	Channel 54 fader	0-127
54	36	CROSSFADE slider	0-127 (1)
55	37	MASTER fader	0-127
56	38	SUBMASTER A fader	0-127
57	39	SUBMASTER B fader	0-127
58	3A	Chase LEVEL fader	0-127
59	3B	Chase RATE fader	0-127
60	3C	Channel 1 BUMP button	0=Off, 127=On
61	3D	Channel 2 BUMP button	0=Off, 127=On
62	3E	Channel 3 BUMP button	0=Off, 127=On
63	3F	Channel 4 BUMP button	0=Off, 127=On
64	40	Channel 5 BUMP button	0=Off, 127=On
65	41	Channel 6 BUMP button	0=Off, 127=On
66	42	Channel 7 BUMP button	0=Off, 127=On
67	43	Channel 8 BUMP button	0=Off, 127=On
68	44	Channel 9 BUMP button	0=Off, 127=On
69	45	Channel 10 BUMP button	0=Off, 127=On
70	46	Channel 11 BUMP button	0=Off, 127=On
71	47	Channel 12 BUMP button	0=Off, 127=On
72	48	Channel 13 BUMP button	0=Off, 127=On
73	49	Channel 14 BUMP button	0=Off, 127=On
74	4A	Channel 15 BUMP button	0=Off, 127=On
75	4B	Channel 16 BUMP button	0=Off, 127=On
76	4C	Channel 17 BUMP button	0=Off, 127=On
77	4D	Channel 18 BUMP button	0=Off, 127=On
78	4E	Channel 19 BUMP button	0=Off, 127=On
79	4F	Channel 20 BUMP button	0=Off, 127=On
80	50	Channel 21 BUMP button	0=Off, 127=On
81	51	Channel 22 BUMP button	0=Off, 127=On
82	52	Channel 23 BUMP button	0=Off, 127=On
83	53	Channel 24 BUMP button	0=Off, 127=On
84	54	Channel 25 BUMP button	0=Off, 127=On
85	55	Channel 26 BUMP button	0=Off, 127=On
86	56	Channel 27 BUMP button	0=Off, 127=On
87	57	Channel 28 BUMP button	0=Off, 127=On
88	58	Channel 29 BUMP button	0=Off, 127=On
89	59	Channel 30 BUMP button	0=Off, 127=On
90	5A	Channel 31 BUMP button	0=Off, 127=On
91	5B	Channel 32 BUMP button	0=Off, 127=On
92	5C	Channel 33 BUMP button	0=Off, 127=On
93	5D	Channel 34 BUMP button	0=Off, 127=On
94	5E	Channel 35 BUMP button	0=Off, 127=On
95	5F	Channel 36 BUMP button	0=Off, 127=On
96	60	Channel 37 BUMP button	0=Off, 127=On
97	61	Channel 38 BUMP button	0=Off, 127=On
98	62	Channel 39 BUMP button	0=Off, 127=On
99	63	Channel 40 BUMP button	0=Off, 127=On

APPENDIX 1, CONTINUED

Controller No. (Decimal) (Hex)	LM-850 Function	Possible Values (Decimal)
100 64	Channel 41 BUMP button	0=Off, 127=On
101 65	Channel 42 BUMP button	0=Off, 127=On
102 66	Channel 43 BUMP button	0=Off, 127=On
103 67	Channel 44 BUMP button	0=Off, 127=On
104 68	Channel 45 BUMP button	0=Off, 127=On
105 69	Channel 46 BUMP button	0=Off, 127=On
106 6A	Channel 47 BUMP button	0=Off, 127=On
107 6B	Channel 48 BUMP button	0=Off, 127=On
108 6C	Channel 49 BUMP button	0=Off, 127=On
109 6D	Channel 50 BUMP button	0=Off, 127=On
110 6E	Channel 51 BUMP button	0=Off, 127=On
111 6F	Channel 52 BUMP button	0=Off, 127=On
112 70	Channel 53 BUMP button	0=Off, 127=On
113 71	Channel 54 BUMP button	0=Off, 127=On
114 72	CHASE On/Off	17=pressed
	CLOCK button	34=pressed
	AUDIO button	68=pressed
	Master BUMP button	17=pressed, 16=released
115 73	Submaster A BUMP	34=pressed, 32=released
	Submaster B BUMP	68=pressed, 64=released
116 74	Chase BUMP button	0=Off, 127=On
117 75	BLACKout button	127=pressed, 0=released (2)
118 76	BUMP ALL button	127=pressed, 0=released (2)
119 77	CLEAR button	127=pressed
120 78	GO button	127=pressed (3)
121 79	Scene/Song mode buttons	0=Song mode (4), 127=Scene mode

NOTES:

(1) When in Scene mode, the CROSSFADE slider sends a program change number following the initial controller message.

(2) Release message is only sent for MOMentary mode. If button is held down while in LATCH mode, a second "pressed" message is sent after 1/4 second to override timed fades.

(3) Controller message sent in Song mode only. In Scene mode, GO button sends program changes which designate scene number.

(4) Song mode command is followed by a program change byte.

The following panel controls have no associated MIDI function:

BANK switches
LATCH/MOM
SOLO/ADD

UP/DOWN and NEXT/LAST
CONSOLE & CHASE mode
Cursor LEFT/RIGHT

STORE
MANUAL
Keypad

TEMPO
SENSE
HELP



35 SOUTH 40TH STREET
 PHOENIX, ARIZONA 85036
 Phone: (602) 267-1000

SPR IN ADVANCE
 SOLD TO PHOENIX, AZ 85061

SPHE VASULKAS INC
 RT. 6 BOX 100
 PATTN: WOODY
 SANTA FE, N.M. 87501

PART NUMBER	STOCK IN	STOCK OUT
Printed On 10/23/92		

PURCHASE ORDER _____ INVOICE NUMBER T-17503-0
 SPECIAL INSTRUCTIONS:
PLEASE SHIP FED EX SATURDAY

ENTERED BY	DATE ENTERED	TIME PRINTED	DATE REQUIRED	FREIGHT TERMS	F.O.B.	ACCOUNT NUMBER	CTL# 242075	START	FINISH	
RJH	10/23/92	11:57	10/23/92	SP/FA	X	351500				
QUANTITY ORDERED							SELECTION TIME:			
QUANTITY SHIPPED							DELIVERED TIME:			
UNIT	✓	PART NUMBER/DESCRIPTION					INS/LOC	UNIT PRICE	U	EXTENDED AMOUNT

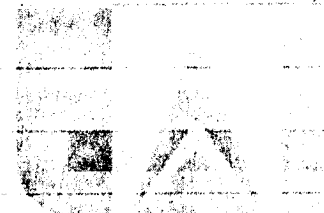
500	500 FT	✓	DELIVERY 10-23-92 ON ACCOUNT # 10981657-4. THANKS RJH 18/2 SVT 250 SPOOLS THANK YOU FOR THE ORDER ** ORDER WAS CONFIRMED TO ** ** At 11:57 AM on October 23, 1992 **  250. 18-2 SVT. J 6754A						140.00	70.00
INSPECTION FOR CONCEALED DAMAGE OR SHORTAGE MUST BE MADE AND REPORTED WITHIN 6 DAYS AFTER DELIVERY.			RECEIVED IN GOOD CONDITION PLEASE PRINT NAME LEGIBLY AND INITIAL							

NO. OF CARTONS	COILS	REELS	BUNDLES	WEIGHT	SHIP VIA	DATE SHIPPED	SELECTED BY	CHECKED BY	PACKED BY	SHIPPER	AMOUNT
10 in				18	SAT DEL FED EX	10-23-92	RLR	RLR	RLR	RLR	70.00
CUSTOMER COPY / PACKING LIST											



35 SOUTH 40TH STREET
 PHOENIX, ARIZONA 85036
 Phone: (602) 267-1000

SP
 LD
 1
 1
 0
 PHOENIX, AZ 85061

SP
 HP
 RT. 6 BOX 100
 P
 ATTN: WOODY
 O
 SANTA FE, N.M. 87501

PART NUMBER	STOCK IN	STOCK OUT
Printed On 10/23/92		

PURCHASE ORDER _____ INVOICE NUMBER 1-17505-0

SPECIAL INSTRUCTIONS:
PLEASE SHIP FED EX SATURDAY

ENTERED BY	DATE ENTERED	TIME PRINTED	DATE REQUIRED	FREIGHT TERMS	F.O.B.	ACCOUNT NUMBER	CTL# 242075	START	FINISH
RJH	10/23/92	11:57	10/23/92	SP/FA	X	351500			
QUANTITY ORDERED							SELECTION TIME:		
QUANTITY SHIPPED							DELIVERED TIME:		

QUANTITY ORDERED	QUANTITY SHIPPED	UNIT	PART NUMBER/DESCRIPTION	INS/LOC	UNIT PRICE	U	EXTENDED AMOUNT
500	500	ft	DELIVERY 10-23-92 ON ACCOUNT # 10981657-4. THANKS RJH 18 1/2 SVT 250 SPOOLS THANK YOU FOR THE ORDER ! ** ORDER WAS CONFIRMED TO ** ** At 11:57 AM on October 23, 1992 **		140.00		70.00

INSPECTION FOR CONCEALED
 DAMAGE OR SHORTAGE MUST BE
 MADE AND REPORTED WITHIN 6
 DAYS AFTER DELIVERY.

RECEIVED IN
 GOOD CONDITION

PLEASE PRINT NAME LEGIBLY AND INITIAL

NO. OF CARTONS	COILS	REELS	BUNDLES	WEIGHT	SHIP VIA	DATE SHIPPED	SELECTED BY	CHECKED BY	PACKED BY	SHIPPER	AMOUNT
10EW				18	SAT DEL FED EX	10-23-92	ELK	ELK	ELK	ELK	70.00
CUSTOMER COPY / PACKING LIST											

RELIANCE 6718 JEFFERSON

800 999-8405

10
20 - $1/8 \times 1/2 \times 12'$ #75
3 - ~~45~~ $1/8 \times 5/8 \times 5/8$ L 10' ~~55~~
64"

~~DALE~~
DALE

BARHILL BOCT

PRINCETON BETWEEN
MENARD + CAUDELANIA

REGAL - STEVE 4/13
TRANSWHITE STYRENE.

41" x 96" #25841 ←
48" x 96" #5686

HAMILTON 1-700-757 6603

2924

473 6614

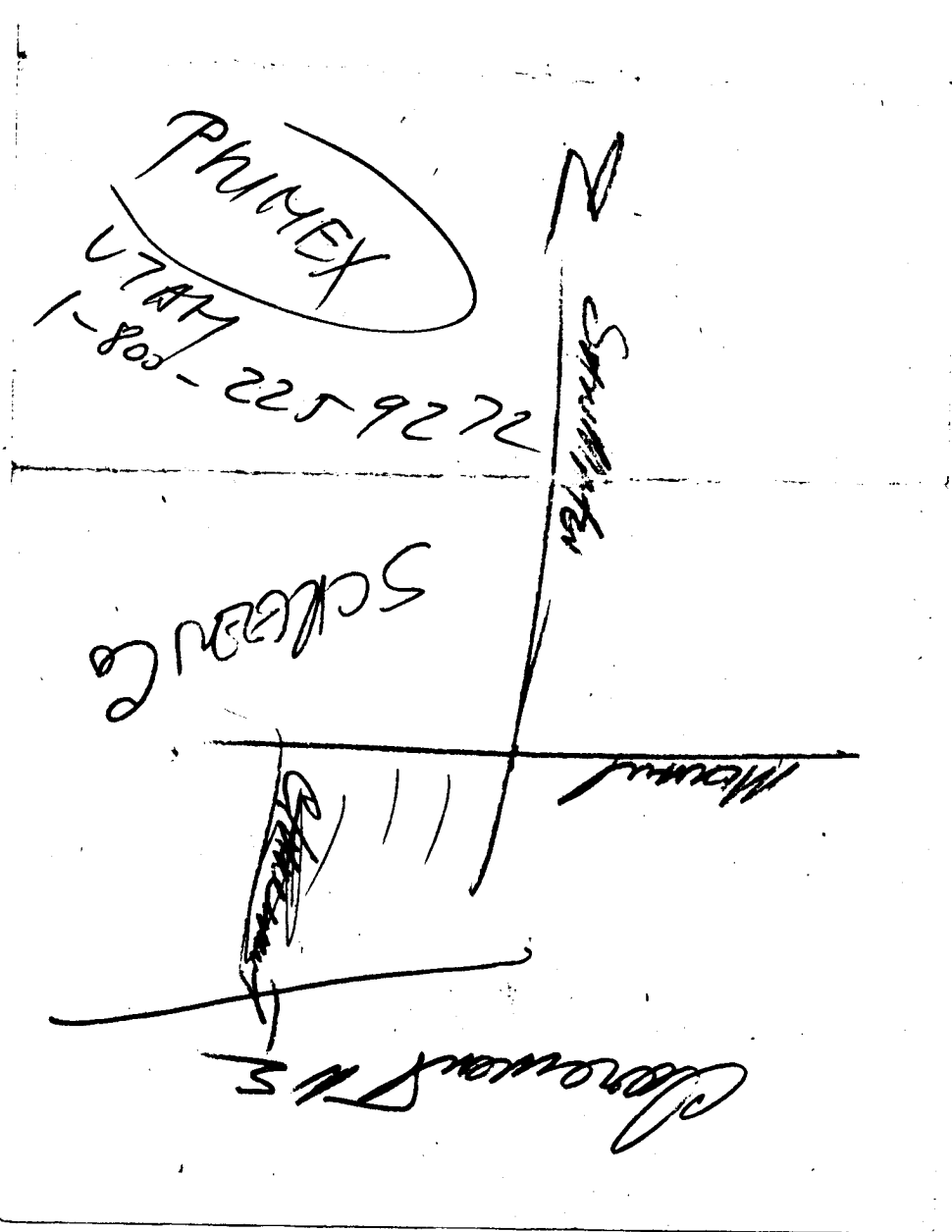



CONTROL

WORK ORDER

ORDER DATE	04/28/93	WORK NO.	142395
SHIP TO	ALBUQUERQUE	PAGE	1

SOLD TO: 10896
 ALBUQUERQUE C.O.D. RETAIL
 TAXABLE
 ALBUQUERQUE, NM

SHIP TO:
 WOODY
 100 AGUA FRIA
 NEAR SAN YSIDRO
 AND A CHURCH
 471-7181

CS

QUANTITY ORDERED	QUANTITY SHIPPED	PROD REF	PRODUCT DESCRIPTION	UNIT CODE	UNIT PRICE	EXTENDED AMOUNT
3.00	3.00	25841	STYRENE TRANSPARENT .020 X 41 X 96	SHT	5.0000	15.00
			** SUBTOTAL **			15.00
			NEW MEXICO SALES TAX		5.81	0.87
			** TOTAL INVOICE **			15.87

TERMS COLLECT ON DELIVERY

SHIP CODE

SHIP VIA TRUCK

BUYER

REQUESTED SHIP DATE

CUSTOMER NO

Pl. # 3143

Shank

UNIT CODE LEGEND
 SH - SHEET
 SF - SQUARE FOOT
 FT - FOOT
 LB - POUND
 RL - ROLL
 QT - QUART
 GL - GALLON
 PT - PINT
 EA - EACH

RECEIVED BY

FILLED BY

CHECKED BY / DRIVER

DENVER: 5251 S. Rio Grande, Littleton, CO 80120
COLORADO SPRINGS: 702 Nichols Blvd., Colorado Springs, CO 80907
EL PASO: 10871 Pelicano Dr., El Paso, TX 79935
ALBUQUERQUE: 3455 Princeton NE, Albuquerque, NM 87107
LOS ANGELES: 14709 Spring Ave., Santa Fe Springs, CA 90670
PHOENIX: 3210 Rosser Rd. Ste. 5, Phoenix, AZ 85040
SAN DIEGO: 8651 Production Ave., San Diego, CA 92121
AUTHORIZED RETURN SUBJECT TO 20%

regal
PLASTICS

CONTROL

WORK ORDER

ORDER DATE 04/28/93
 ORDER NO. 142395
 SHIPPED FROM ALBUQUERQUE
 PAGE 1

CS

SOLD TO: 10896
 ALBUQUERQUE C.O.D. RETAIL
 TAXABLE
 ALBUQUERQUE, NM

SHIP TO:
 WOODY
 100 AGUA FRIA
 NEAR SAN YSIDRO
 AND A CHURCH
 471-7181

QUAN ORDERED	QUAN SHIPPED	PROD REF	PRODUCT DESCRIPTION	UNIT CODE	UNIT PRICE	EXTENDED AMOUNT
3.00	3.00	25841	STYRENE TRANSPARENT .020 X 41 X 96	SHT	5.0000	15.00
			** SUBTOTAL **			15.00
			NEW MEXICO SALES TAX		5.81	0.87
			** TOTAL INVOICE **			15.87

PD # 3143

Shadwell

TERMS: **COLLECT ON DELIVERY**

SHIP CODE: **U**

SALES MAN: **SALES MAN**

REGISTERED SHIPPER: **3143**

BUYER: **WOODY**

SPECIAL INSTRUCTIONS:

RECEIVED BY: _____

FILLED BY: _____

CHECKED BY: **DRIVER**

DENVER: 5251 S. Rio Grande, Littleton, CO 80120

COLORADO SPRINGS: 702 Nichols Blvd, Colorado Springs, CO 80907

EL PASO: 10871 Pellicano Dr, El Paso, TX 79935

ALBUQUERQUE: 3455 Princeton Ave, Albuquerque, NM 87107

LOS ANGELES: 14709 Spring Ave, Santa Fe Springs, CA 90670

PHOENIX: 3210 Roesser Rd, Ste. 5, Phoenix, AZ 85040

SAN DIEGO: 8651 Production Ave, San Diego, CA 92121

AUTHORIZED RETURN SUBJECT TO 20%

Scientific 609-573-6250 Fax-609-573-6295 Cable EDSCORP

407017419 01938047
 BOHUSLAV VASULKA
 RR 6 BOX 100
 SANTA FE, NM 87501

SHIP
 BOHUSLAV VASULKA
 RR 6 BOX 100
 SANTA FE, NM 87501

INFORMATION
 ON
 REVERSE
 SIDE

PACKING SLIP

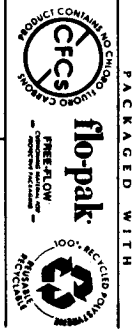

QTY.	ITEM	DESCRIPTION	UNIT PRICE	AMOUNT
1	61260	MUST SHIP 3/15/94 12:30	31.80	31.80
1	A3362	SHIP UPS BLUE LABEL ONLY	31.80	31.80
2		40/60 BEAM SPLIT AR 5 X 7 BEAM SPLITTER 127X178X3		

SSS 498
 USA

RECEIVED
 1/21/94

Order Date: 03/15/94
 Key: 14NIN900
 03/15/94

Page : 1 Last page

Total Product 63.60
 Tax 14.50
 Postage + Handling 78.10
 Total Charge

Edmund Scientific Company
 101 East Gloucester Pike
 Barrington, New Jersey 08007-1380 U.S.A.

UPS BLUE
 NJ 069-507
 PACKAGE-938047A-1

SHIP TO

BOHUSLAV VASULKA

THE VASULKAS

539651
ORDER #

61260



0 00131 35077 7
40/60 BEAM SPLIT AR 5 X 7

03) 01-08-H21

40/60 BEAM SPLIT AR 5 X 7
01S38047 010432 9

61260

43362



0 00133 43739 1
BEAM SPLITTER 127X178X3

03) 01-09-I43

BEAM SPLITTER 127X178X3
01S38047 010432 11

43362

Beam Splitters - Filters

MIRROR TYPE BEAM SPLITTERS

Mirror type beam splitters are an optical window with a semi-transparent mirrored coating to break a beam into two or more separate beams. A beam splitter will reflect a portion of the incident energy (see reflectivity %), absorb a relatively small portion, and transmit the remaining energy (see transmission %). Mirror type beam splitters have very neutral color characteristics. Interference coatings are extra durable. Glass is parallel to 20 seconds. Surface flat to approximately 10 wavelengths. See Index for photographic special affects application.

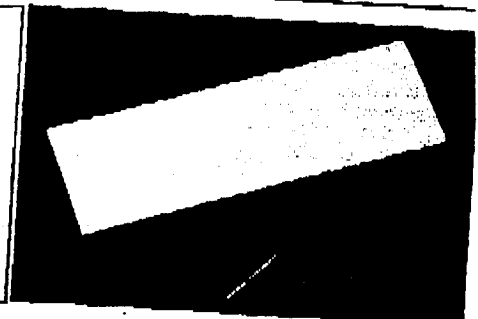
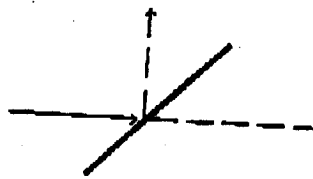

Commercial Grade (Standard Design - Unlimited Supply)

STOCK #	SIZE (MM)	REFLEC-TIVITY%	TRANS-MISSION	COM-MENTS	PRICE
G31,416	12 x 19 x 1	10	90		\$10.90
G31,414	18 x 30 x 2	50	50		10.90
G32,269	20 x 27 x 1	50	50		10.90
G31,413	20 x 37 x 1	50	50		11.85
G31,412	25 x 28 x 1	30	70		11.85
G32,363	25 x 38 x 1.5	45	45		12.15
G31,411	25 x 78 x 2	50	50		12.65
G43,358	50 x 50 x 1	40	60		12.85
G43,359	50 x 50 x 1	50	50		12.85
G43,360	60 x 50 x 1	30	70		12.85
G61,097	127 x 178 x 3	30	70		12.85
G43,362	127 x 178 x 3	30	70	AR CTD	31.80
G61,260	127 x 178 x 3	30	70	AR CTD	31.80
G72,500	254 X 356 x 3	30	70	AR CTD	85.00
G43,363	254 x 356 x 3	30	70	AR CTD	85.00
G72,502	254 X 356 x 3	40	60	AR CTD	85.00

MIRROR TYPE BEAM SPLITTERS

Experimental Grade (Various Grades - Limited Quantities)

STOCK #	SIZE (MM)	REFLEC-TIVITY%	TRANS-MISSION	PRICE
G31,415	15 DIA. X 2	10	90	\$10.00
G30,725	22 X 30 X 2	30	70	10.90
G31,437	25 X 38 X 3	25	75	13.25
G31,436	25 X 38 X 3	50	50	12.65
G31,435	25 X 38 X 2	75	25	12.66
G31,434	51 X 76 X 3	25	75	19.55
G31,433	51 X 76 X 3	50	50	19.55
G31,432	51 X 76 X 3	75	25	19.55
G578	67 X 83 X 6	30	30	13.60
G31,410	77 DIA. X 2	20	80	16.35

COLOR SEPARATING DICHOIC FILTER

Used primarily in sets, these filters provide excellent color separation for display systems, light balancing, color correction and a host of other color lighting needs. Filter coatings are applied on a 50mm x 55mm x 1.15mm low expansion Borasilicate Substrate (coming 7059-F) thereby, making it possible to subject them to moderate amounts of heat without damage. Setups like that shown in the application drawing will provide rich primary colors that can then be recombined producing any color desired. Each \$13.00

- A) 45 Degree Blue Reflector G43,454
- B) 45 Degree Red Reflector G43,455
- C) Blue Corrector G43,456
- D) Red Corrector G43,457
- E) Green Corrector G43,458

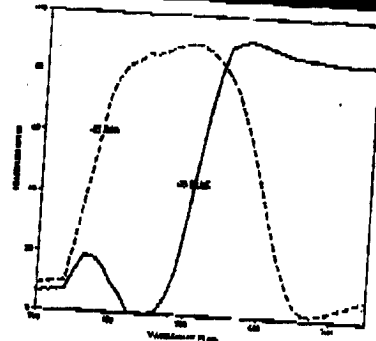
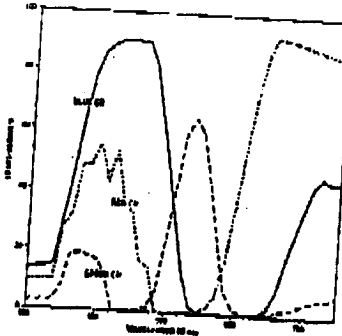
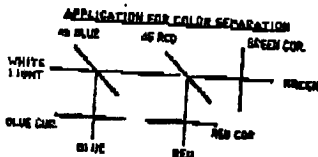

DICHOIC HIGH COLOR SATURATION FILTERS

These elements reflect from the front coated surface at least 90% of the incident light at the specified wavelength which includes a tolerance of ± 15 microns.

- SPECIFICATIONS:**
 Dimensions: 2" x 2" x 1/16"
 Material: Float Glass (n = 1.523)
 Surface Quality: 80 - 50 Scratch-Dig
 Temperature Range: Minus 60°F to 500°F
 Reflection: 90% ± 15 microns (0° incidence)

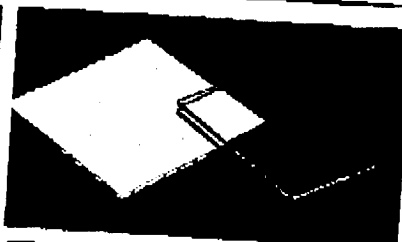

CENTRAL COLOR	STOCK NUMBER	PRICE (EACH)		
		1 - 9	10 - 49	50+
Red	G30,634	\$20.75	\$19.00	\$17.00
Blue	G30,635	\$20.75	\$19.00	\$17.00
Yellow	G30,637	\$20.75	\$19.00	\$17.00
Cyan	G39,912	\$20.75	\$19.00	\$17.00
Magenta	G39,913	\$20.75	\$19.00	\$17.00

LARGE 5 1/2" DIAMETER INFRARED FILTER

- Experimental Grade Optics

Designed as the front light source filter for a military infrared viewer, this large 5 1/2" diameter x 1/8" thick filter is coated on the face surface and allows only long wavelength infrared light to pass. In total darkness the amount of visible light passing through the filter from a high intensity portable search lantern is indiscernible at 20 feet.



Filter G60,033 \$32.50

Beam Splitters - Filters

MIRROR TYPE BEAM SPLITTERS

Mirror type beam splitters are an optical window with a semi-transparent mirrored coating to break a beam into two or more separate beams. A beam splitter will reflect a portion of the incident energy (see reflectivity %), absorb a relatively small portion, and transmit the remaining energy (see transmission %). Mirror type beam splitters have very neutral color characteristics. Interference coatings are extra durable. Glass is parallel to 20 seconds. Surface flat to approximately 10 wavelengths. See Index for photographic special effects application.

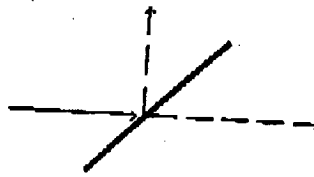

Commercial Grade (Standard Design - Unlimited Supply)

STOCK #	SIZE (MM)	REFLECTIVITY%	TRANSMISSION	COMMENTS	PRICE
G31,410	12 x 19 x 1	10	90		\$10.90
G31,414	18 x 30 x 2	50	50		10.90
G32,269	20 x 27 x 1	50	50		10.90
G31,413	20 x 37 x 1	50	50		11.85
G31,412	25 x 28 x 1	30	70		11.85
G32,363	25 x 38 x 1.5	45	45		12.15
G31,411	25 x 76 x 2	50	50		12.85
G43,358	50 x 50 x 1	40	60		12.85
G43,359	50 x 50 x 1	50	50		12.85
G43,360	50 x 50 x 1	30	70		12.85
G61,097	127 x 178 x 3	30	70		12.85
G48,362	127 x 178 x 3	30	70	AR CTD	31.80
G61,260	127 x 178 x 3	30	70	AR CTD	31.80
G72,500	254 x 356 x 3	30	70	AR CTD	85.00
G43,363	254 x 356 x 3	30	70	AR CTD	85.00
G72,502	254 x 356 x 3	40	60	AR CTD	85.00

MIRROR TYPE BEAM SPLITTERS

Experimental Grade (Various Grades - Limited Quantities)

STOCK #	SIZE (MM)	REFLECTIVITY%	TRANSMISSION	PRICE
G31,415	15 DIA. X 2	10	90	\$10.00
G30,725	22 X 30 X 2	30	70	10.90
G31,437	25 X 38 X 3	25	75	13.25
G31,436	26 X 38 X 3	50	50	12.65
G31,438	25 X 38 X 3	75	25	12.65
G31,434	51 X 76 X 3	25	75	19.55
G31,433	51 X 76 X 3	50	50	19.55
G31,432	51 X 76 X 3	75	25	19.55
G578	67 X 83 X 5	30	30	13.60
G31,410	77 DIA. X 2	20	80	16.35

COLOR SEPARATING DICHOIC FILTER

Used primarily in sets, these filters provide excellent color separation for display systems, light balancing, color correction and a host of other color lighting needs. Filter coatings are applied on a 50mm x 55mm x 1.15mm low expansion Borasilicate Substrate (coming 7059-F) thereby, making it possible to subject them to moderate amounts of heat without damage. Setups like that shown in the application drawing will provide rich primary colors that can then be recombined producing any color desired. Each \$13.00

- A) 45 Degree Blue Reflector G43,454
- B) 45 Degree Red Reflector G43,455
- C) Blue Corrector G43,456
- D) Red Corrector G43,457
- E) Green Corrector G43,458

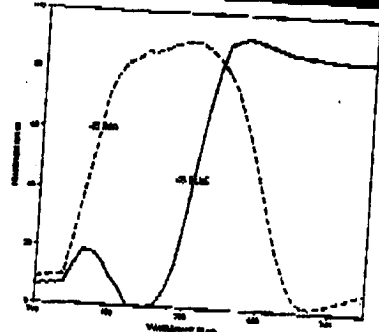
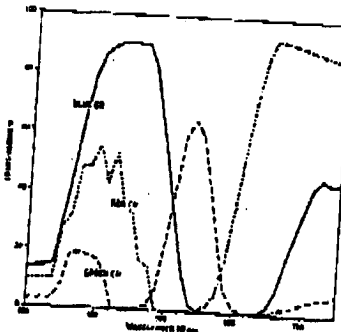
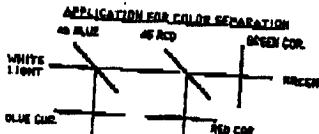

LARGE 5 1/2" DIAMETER INFRARED FILTER

Experimental Grade Optics
Designed as the front light source filter for a military infrared viewer, this large 5 1/2" diameter x 1/8" thick filter is coated on the face surface and allows only long wavelength infrared light to pass. In total darkness the amount of visible light passing through the filter from a high intensity portable search lantern is indiscernible at 20 feet.

Filter G60,033 \$32.50

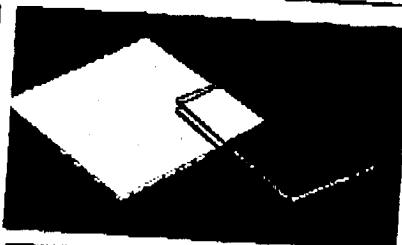

DICHOIC HIGH COLOR SATURATION FILTERS

These elements reflect from the front coated surface at least 90% of the incident light at the specified wavelength which includes a tolerance of ± 15 microns.

SPECIFICATIONS:
 Dimensions: 2" x 2" x 1/16"
 Material: Float Glass (n = 1.523)
 Surface Quality: 80 - 50 Scratch-Dig
 Temperature Range: Minus 80°F to 500°F
 Reflection: 90% ± 15 microns (0° incidence)

CENTRAL COLOR	STOCK NUMBER	PRICE (EACH)		
		1 - 9	10 - 49	50+
Red	G30,634	\$20.75	\$19.00	\$17.00
Blue	G30,635	\$20.75	\$19.00	\$17.00
Yellow	G30,637	\$20.75	\$19.00	\$17.00
Cyan	G39,912	\$20.75	\$19.00	\$17.00
Magenta	G39,913	\$20.75	\$19.00	\$17.00